



Integrated Substation Network Architectures

Substation Data Networks
and IEC 61850

By Ted Witham



Table of Contents

- Background.....Slide 4
- Serial Based Substation.....Slide 5
- The Power of Standards.....Slide 6
- Transitional Substation c1999.....Slide 7
- Transitional Architecture.....Slide 8
- Power Networks & Data Networks...Slide 9
- Complementary Market Forces.....Slide 10
- Current and Future Substation.....Slide 11



Table of Contents

- 61850 Architecture.....Slide 12
- Utility Example: Elektro Guaruja Ethernet Architecture.....Slide 13
- Strategic Data Network Planning.....Slide 14
- 61850 and Security.....Slide 15
- 61850 and “the Grid”.....Slide 16
- Market & Technology Convergence..Slide 17
- Looking Ahead.....Slide 18
- Summary.....Slide 19



Background

- From E/M to Solid State to Today
- Microprocessors and Substation Automation
- Population Growth
- A Changing World
- It's all about the DATA!



Serial Based Substation

- Hard-wired connectivity
- Serial-over-fiber links to distributed devices in facilities
 - Usually point-to-point
 - Usually serial-over-fiber Links/repeaters
- Data comm intelligence constrained to the facility's control room (hut / enclosure)
- Usually dedicated WAN connections from RTUs / data comm processors
 - Analog leased lines
 - Dial-up modems

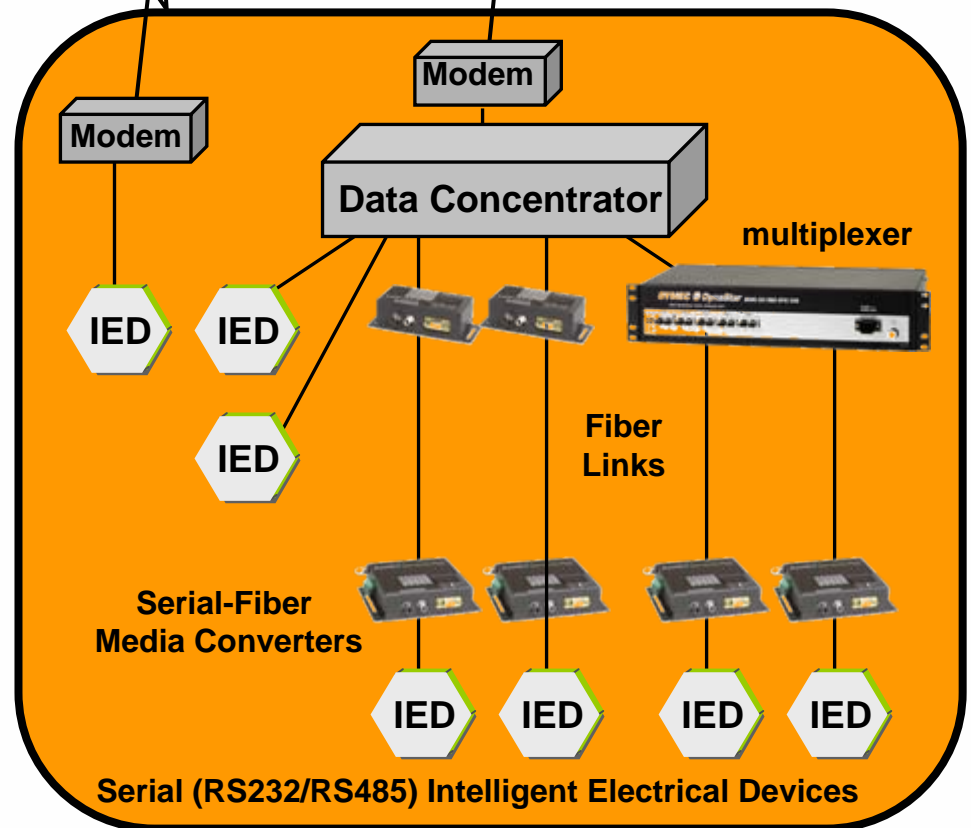

The Power of Standards

- IEC, IEEE, ANSI, EPRI, KEMA, CIGRE
-years ago separate standards on
separate continents seemed ok
- Today, a global business environment,
“flat world” drives us to convergence
- Support of companies, vendors and clients
- 61850 is a global standard,
with more to follow



Transitional Substation c1999

- Mixed Ethernet and Serial
- A Substantial Challenge to protect existing investment, but incorporate with a migratable upgrade path
- WAN and SCADA connections are an opportunity for gains and savings
- Who owns what?



Transitional Architecture

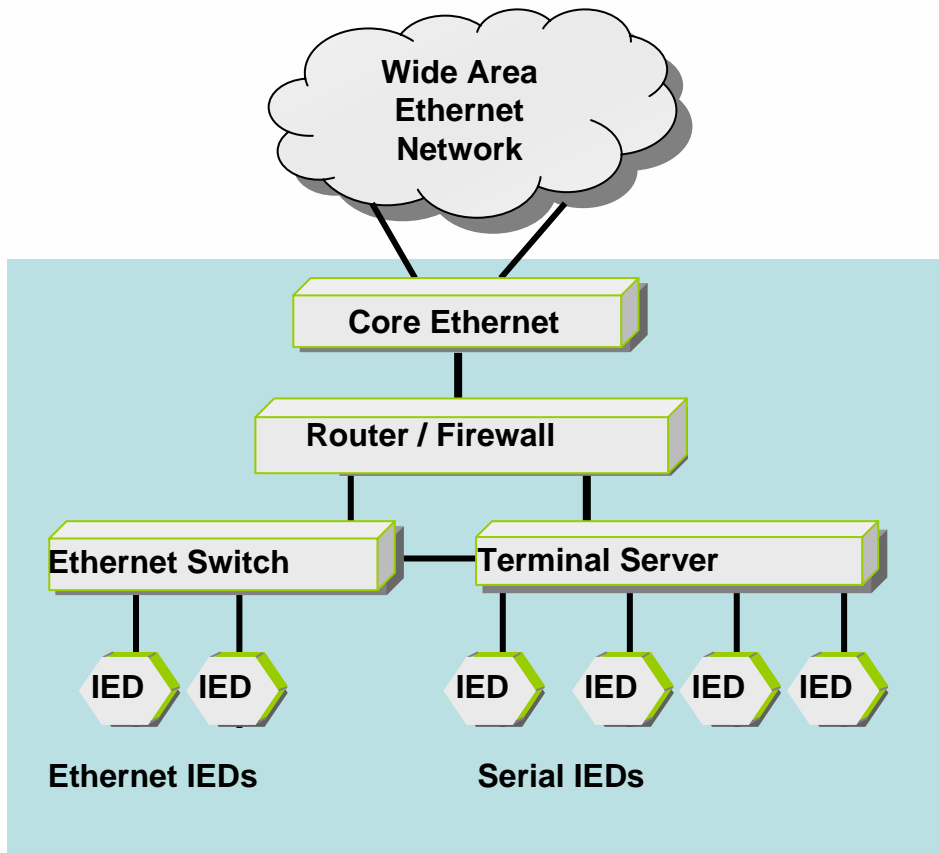

Architecture allows management of both architectures

Routing function and updated Terminal Server allows security to serial devices, software needed

Reserve capacity in Ethernet switch for future expansion to all E-net



Power Networks and Data Networks

- From 7 Kilometers up, the Transmission and Distribution Network start to look like a Data Network!!

WAN to LAN to Subnet =

Generation to Transmission to Distribution

- Distributed generation, Wind Farms, data clusters, ring topology, N+1 reliability



Complementary Market Forces

- Automation
- Interoperability
- Transitional Workforce - the “Microsoft” generation...
- Security
- Ageing Infrastructure and Developing Nations



Current and Future Substation

- WAN with Security, Managed Network inside the firewall
- Minimize Firewall Penetrations
- Push technology for stakeholders
- Operational and Non Operational Data
- N+1 redundancy in both the Power and the Data Networks



61850 Architecture

ICCP, E1, T1, etc.

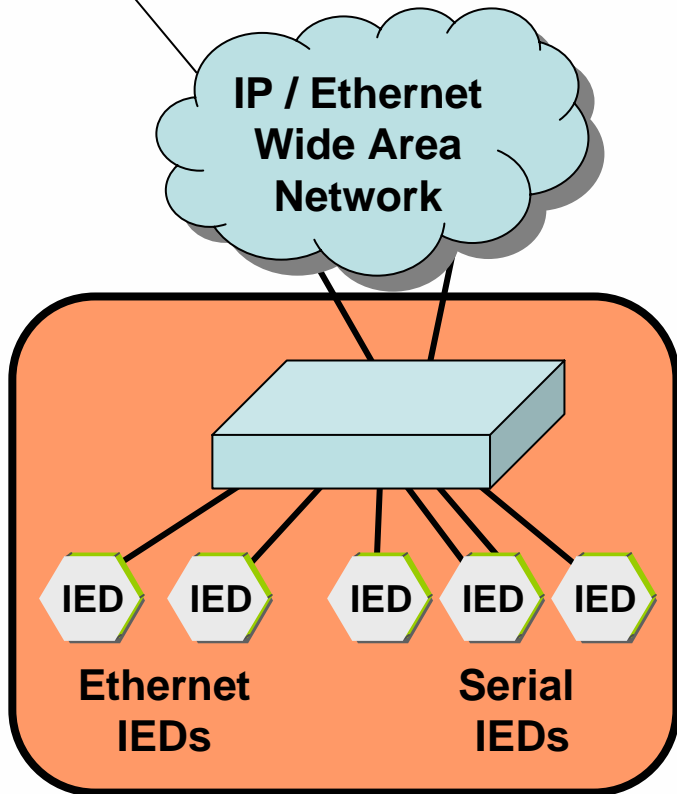

- Allow for serial connections
- Allow for Ethernet, copper or fiber
- Combine Serial Server, Managed Switch, Router, Firewall and WAN connectivity in one intelligent, substation hardened device
- “Can we do that??” Yes, the technology is here now.
- Flexibility for Substation computer, push technology, high cyber security.



Strategic Data Network Planning

- Choose your Standards
- Greenfield versus Retrofit
- Forecasting Functionality
- Pressures that Challenge Strategic Planning
- TCO – Total Cost of Ownership
Managing Planning, Projects, Technology and Suppliers

Elektro Electricidade e Serviços
30 Substation IEC 61850 Project



POWERGRID
EUROPE

26 – 28 June 2007 | Feria de Madrid | Madrid, Spain

61850 and Security

- WAN/Firewall/Managed Network is a security enabling architecture
- Physical environment considerations
- The value of the network itself and the Data it carries is now a critical assett



61850 and “the Grid”

1. Power Infrastructure

2. Information Infrastructure

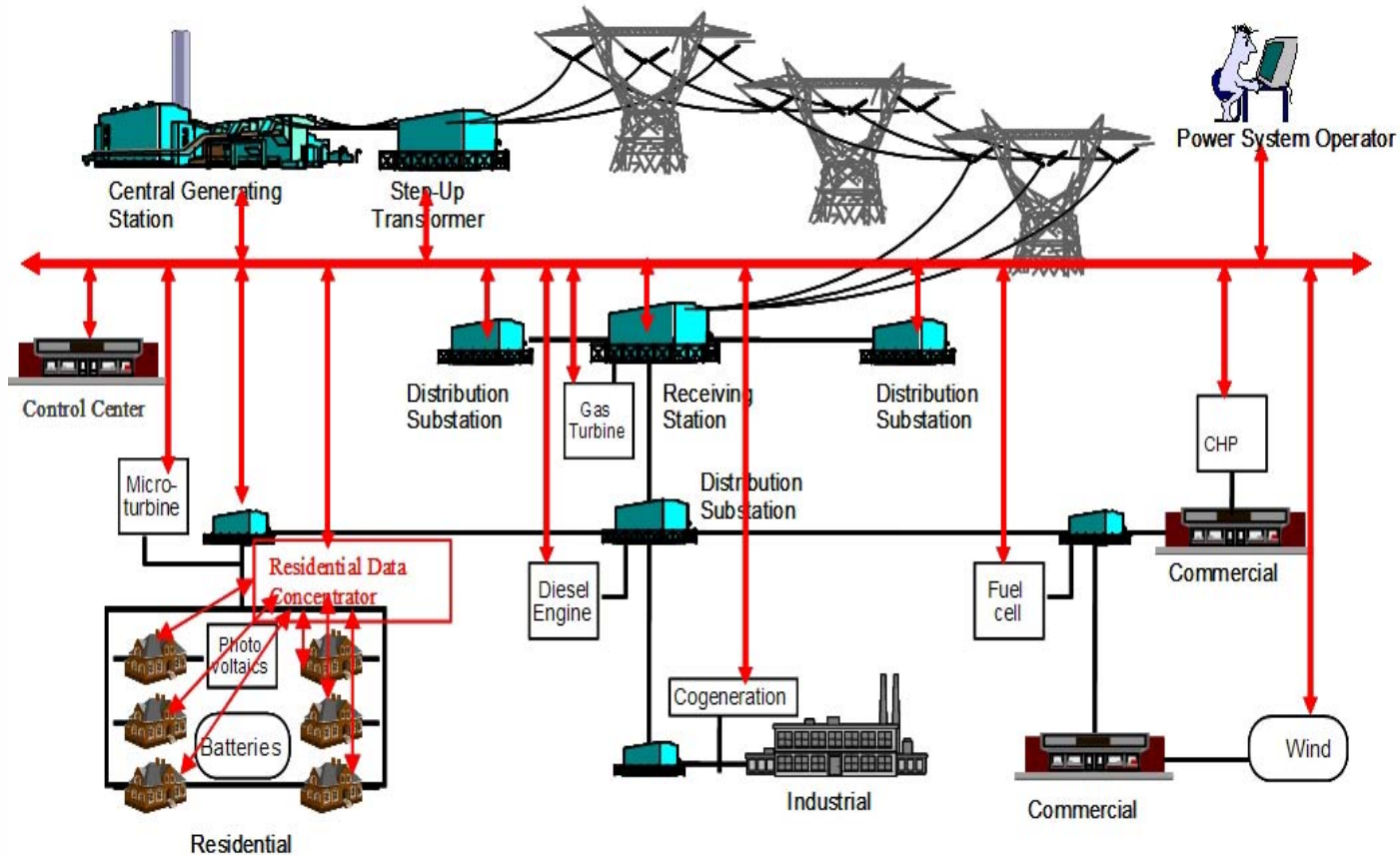

Source:
EPRI

POWERGRID
EUROPE

26 – 28 June 2007 | Feria de Madrid | Madrid, Spain

Market and Technology Convergence

- As Deregulation and Specialization Occur in Power Systems
- So Technology Gains and Converges to:
- Where the efficient market finds the best fit Technology, and Vice Versa
- Standards both accelerate and stabilize that process



Looking Ahead

- Convergence of IT and Telecom and Integration into Operations
- Managing Technology, and Game Changers
- What will the Utility Data Network look like in 10 years? Voice over IP, IP Video, Wireless, Broadband PLC, Demand Management, Last Mile technologies...



Summary

- The rate of change increases, with benefits and risks
- Standards help the industry manage technology risk, and maximize benefit – particularly Global Standards!
- Suppliers and Clients participate and benefit together
- Creating Sustainable Standards is Today's Challenge





Thank You!

Ted Witham, PE

Director of International Business Development

GarrettCom, Inc.

WWW.GarrettCom.com

twitham@GarrettCom.com

