

Declarations

DOCUMENT NOTICE

Copyright

Copyright 2007 by GarrettCom. Printed in the US. All rights reserved.

This manual may not be reproduced or disclosed in whole or in part by any means without the written consent of GarrettCom. DynaStar is a trademark of Garrett. All other trademarks mentioned in this document are the property of their respective owners.

This document has been prepared to assist users of equipment manufactured by GarrettCom and changes are made periodically to the information in this manual. Such changes are published in Software Release Notices. If you have recently upgraded your software, carefully note those areas where new commands or procedures have been added. The material contained in this manual is supplied without any warranty of any kind. GarrettCom therefore assumes no responsibility and shall incur no liability arising from the supplying or use of this document or the material contained in it.

Rights

Except as set forth in the Software License Agreement, GarrettCom makes no representation that software programs and practices described herein will not infringe on existing or future patent rights, copyrights, trademarks, trade secrets or other proprietary rights of third parties and GarrettCom makes no warranties of any kind, either express or implied, and expressly disclaims any such warranties, including but not limited to any implied warranties of merchantability or fitness for a particular purpose and any warranties of non-infringement. The descriptions contained herein do not imply the granting of licenses to make, use, sell, license or otherwise transfer GarrettCom products described herein. GarrettCom disclaims responsibility for errors which may appear in this document, and it reserves the right, in its sole discretion and without notice, to make substitutions and modifications in the products and practices described in this document.

Part Number Information

Paper Version Part Number: 3-01-2127-00 Rev AB

CD Part Number: 3-01-2115-00 Rev AB

Revision History

Release Date	Document Revision	Software Release	Change Note
October, 2006	01	1.1	New product release, Hardware and Software
January, 2007	02	1.2	New product release, Hardware and Software
February, 2007	AA	1.2	New product release, Hardware and Software
June, 2007	AB	1.3	Added dimensional drawings, minor edits.

WARRANTY

GarrettCom warrants equipment manufactured by it to be free from defects in materials and workmanship for a period of three (3) years from date of shipment. If within the warranty period the purchaser discovers such item was not as warranted above and promptly notifies GarrettCom in writing, GarrettCom shall repair or replace the items at the company's option. This warranty shall not apply to: (a) equipment not manufactured by GarrettCom; (b) equipment which shall have been repaired or altered by anyone other than GarrettCom; (c) equipment which shall have been subjected to negligence, accident, or damage by circumstances beyond GarrettCom control, or to improper operation, maintenance or storage, or to other than normal use or service. With respect to equipment sold but not manufactured by GarrettCom, the warranty obligation of GarrettCom shall, in all aspects, conform and be limited to the warranty actually extended to GarrettCom by its supplier.

The foregoing warranties do not cover reimbursement for labor, transportation, removal, installation, or other expenses that may be incurred in connection with repair or replacement.

THE FOREGOING WARRANTIES ARE EXCLUSIVE AND IN LIEU OF ALL OTHER EXPRESS AND IMPLIED WARRANTIES EXCEPT WARRANTIES OF TITLE, INCLUDING, BUT NOT LIMITED TO, IMPLIED WARRANTIES OF MERCHANTABILITY AND FITNESS FOR A PARTICULAR PURPOSE.

LIMITATION OF LIABILITY

Anything to the contrary herein contained notwithstanding, **GarrettCom, ITS CONTRACTORS AND SUPPLIERS OF ANY TIER, SHALL NOT BE LIABLE IN CONTRACT, IN TORT (INCLUDING NEGLIGENCE OR STRICT LIABILITY) OR OTHERWISE FOR ANY SPECIAL, INDIRECT, INCIDENTAL OR CONSEQUENTIAL DAMAGES WHATSOEVER.** The remedies of the purchaser set forth herein are exclusive where so stated and the total cumulative liability of GarrettCom its contractors and suppliers of any tier, with respect to this contract or anything done in connection therewith, such as the use of any product covered by or furnished under the contract, whether in contract, in tort (including negligence or strict liability) or otherwise, shall not exceed the price of the product or part on which such liability is based.

Unless otherwise agreed to in writing by an authorized official of GarrettCom, products sold hereunder are not intended for use in or in connection with a nuclear facility or activity. If so used, GarrettCom disclaims all liability for nuclear damage, injury or contamination, and purchaser shall indemnify GarrettCom against any such liability, whether as a result of breach of contract, warranty, tort (including negligence) or otherwise.

PATENTS

As to equipment proposed and furnished by GarrettCom, GarrettCom shall defend any suit or proceeding brought against purchaser so far as based on a claim that said equipment constitutes an infringement of any patent of the United States, if notified promptly in writing and given authority, information, and assistance at GarrettCom's expense for the defense of the claim. In event of a final award of costs and damages from such a suit, GarrettCom shall pay such award. In event the use of said equipment by purchaser is enjoined in such a suit, GarrettCom shall, at its own expense, and at its sole option either (a) procure for purchaser the right to continue using equipment, (b) modify said equipment to render it non-infringing, (c) replace said equipment with non-infringing equipment, or (d) refund the purchase price (less depreciation) and transportation and installation costs of said equipment. GarrettCom will not be responsible for any compromise or settlement made without its written consent. The foregoing states the entire liability of GarrettCom for patent infringement, and in no event shall GarrettCom be liable if the infringement charge is based on the use of GarrettCom equipment for a purpose other than that for which it was sold by GarrettCom. As to any equipment furnished by GarrettCom to purchaser and manufactured in accordance with designs proposed by purchaser, purchaser shall indemnify GarrettCom against any award made against GarrettCom for patent, trademark, or copyright infringement.

RETURN OF EQUIPMENT

No equipment may be returned without purchaser first obtaining GarrettCom's written Return Material Authorization (RMA). An RMA can be obtained by contacting Sales at 978.688-8807.

Equipment accepted for credit, not involving a GarrettCom error, shall be subject to all the terms of the original purchase contract and to a service charge. Returned equipment must be of current manufacture, unused, and in reasonable condition, securely packed to reach GarrettCom without damage, shipped F.O.B. GarrettCom facility with transportation charges paid, and labeled with Return Material Authorization (RMA) number. Any cost incurred by GarrettCom to put equipment in first class condition will be charged to purchaser.

COMPLIANCE NOTICES

FCC Part 15

This device complies with part 15 of the FCC Rules. Operation is subject to the following two conditions: (1) This device may not cause harmful interference, and (2) this device must accept any interference received, including interference that may cause undesired operation.

Note: This equipment has been tested and found to comply with the limits for a Class A digital device, pursuant to part 15 of the FCC Rules. These limits are designed to provide reasonable protection against harmful interference when the equipment is operated in a commercial environment. This equipment generates, uses and can radiate radio frequency energy and, if not installed and used in accordance with the instruction manual, may cause harmful interference to radio communications. Operation of this equipment in a residential area is likely to cause harmful interference in which case the user will be required to correct the interference at his/her own expense.

In order to maintain compliance with FCC regulations shielded cables must be used for electrical I/O with this equipment. Operation with non-approved equipment or unshielded cables may result in interference to radio and television reception.

Changes or modifications could void the user's authority to operate the equipment. The user is cautioned not to change or modify this product.

IC CS03 (Industry Canada)

This digital apparatus does not exceed the Class A limits for radio noise emissions from digital apparatus set out in the interference-causing equipment entitled “Digital Apparatus”, ICES-003 of the department of Communications (Cet appareil numérique respecte les limites bruits radioélectriques applicables aux appareils numériques de Class A prescrites dans la norme sur le matériel brouilleur: “Appareils Numériques”, NMB-003 édictée par le ministre des Communications).

EN55022

Warning: This is a Class A product. In a domestic environment this product may cause radio interference, in which case the user may be required to take adequate measures.

SAFETY

WARNING: Service to this unit can be made only by factory authorized personnel. Failure to observe this caution can result in malfunction to the unit as well as electrocution to personnel.

Avertissement: Cet appareil ne peut être examiné ou réparé que par un employé autorisé du fabricant. Si cette consigne n’est pas respectée, il y a risque de panne et d’électrocution.

Vorsicht: Dieses Gerät darf nur durch das bevollmächtigte Kundendienstpersonal der fabrik instandgehalten werden. Die Nichtbeachtung dieser Vorschrift kann zu Fehlfunktionen des Gerätes führen und das Personal durch Stromschläge gefährden.

Table 2-1.

Industry Canada Warnings	Avis d’Industrie Canada
<p>Notice:</p> <p>Before installing this equipment, users should ensure that it is permissible to be connected to the facilities of the local telecommunications company. The equipment must also be installed using an acceptable method of connection. The customer should be aware that compliance with the above conditions may not prevent degradation of service in some situations.</p> <p>Repairs to certified equipment should be coordinated by a representative designated by the supplier. Any repairs or alterations made by the user to this equipment, or equipment malfunctions, may give the telecommunications company cause to request the user to disconnect the equipment.</p>	<p>Avis:</p> <p>Avant d’installer ce matériel, l’utilisateur doit s’assurer qu’il est permis de le raccorder aux installations de l’entreprise locale de télécommunication. Le matériel doit également être installé en suivant une méthode acceptée de raccordement. L’abonné ne doit pas oublier qu’il est possible que la conformité aux conditions énoncées ci-dessus n’empêche pas la dégradation du service dans certaines situations.</p> <p>Les réparations de matériel homologué doivent être coordonnées par un représentant désigné par le fournisseur. L’entreprise de télécommunications peut demander à l’utilisateur de débrancher un appareil à la suite de réparations ou de modifications effectuées par l’utilisateur ou à cause de mauvais fonctionnement.</p>
<p>Users should ensure for their own protection that the electrical ground connections of the power utility, telephone lines, and internal metallic water pipe system, if present, are connected together. The precaution may be particularly important in rural areas.</p>	<p>Pour sa propre protection, l’utilisateur doit s’assurer que tous les fils de mise à la terre de la source d’énergie électrique, des lignes téléphoniques et des canalisations d’eau métalliques, s’il y en a, sont raccordés ensemble. Cette précaution est particulièrement importante dans les régions rurales.</p>

Service Personnel Warning

The DX40 may be AC or DC powered. Remove all power connections at the circuit panel before removing the unit.

The installation of this product must comply with all applicable codes and practices specified by the country, city, and operating company in which it is installed.

Grounding

All units requiring grounding. Use a grounding wire with a minimum size of 14 AWG at a maximum length of five feet.

The DX40 is equipped with an external grounding screw (6-32 pan head). The grounding screw should be torqued to 10 inch pounds (1.1 Nm).

CONTACTING GARRETTCOM UTILITY NETWORKS

By Mail:

GarrettCom Utility Networks
25 Commerce Way #1
North Andover, MA 01845

Telephone:

978.688-8807

Fax:

978.688-8771

Website:

www.garrettcom.com

Email:

support@garrettcom.com

Customer support representatives are available during normal business hours, 8 - 5pm EST.

TABLE OF CONTENTS

Preface

About This Manual	ix
Conventions	ix
Related Documents	ix
Web Access	x
Your Comments	x

CHAPTER 1: OVERVIEW

1.1 Overview	1
1.2 Configuration	1
1.2.1 Connectivity	1
1.2.2 Power and Ground	2
1.2.3 Indicators	2
1.2.4 Mounting Options	3
1.3 Specifications	4
1.3.1 Physical	4
1.3.2 Environmental	4
1.3.3 Optical	4
1.3.4 Compliance	5
1.3.5 Power Requirements	5
1.3.6 Ports and External Connectors	6
1.3.7 Indicators	6
1.4 Pinouts	7
1.4.1 RJ45	7
1.4.2 SFP	7
1.4.3 DB9 (Female) – RS232 Serial Ports	8
1.4.4 DB9 (Female) – RS485 Serial Ports	8

CHAPTER 2: INSTALLATION

2.1 Preparing for Installation	9
2.1.1 Tools	9
2.1.2 Site Suitability	9
2.1.3 Wiring and Grounding Guidelines	10
2.1.4 Fiber Optic Safety	11
2.1.5 Fiber Optic Handling	11
2.1.6 External Connections	11
2.2 Unpacking	12
2.2.1 Attaching Optional Ethernet Fiber Optic SFPs	12
2.3 Installation of the DX40 Unit	13
2.3.1 Mounting	13
2.3.1.1 Mounting on a Panel	13
2.3.1.2 Mounting in a DIN Rail System	14
2.3.2 Connecting Facility Power	15
2.3.2.1 Making the Ground and Power Connections	15

CONTENTS

2.3.3	Connecting Network Cables	18
2.3.3.1	Connecting Serial Cables	18
2.3.3.2	Connecting Ethernet Copper Cables	18
2.3.3.3	Connecting Fiber Ethernet Cables	19
2.4	Maintenance	19
2.4.1	Removing the DX40	19
2.4.1.1	Disconnecting Network Cables	20
2.4.1.2	Disconnecting Power and Ground Lines	20
2.4.1.3	Packing the DX40 for Shipment	20
2.4.2	Cleaning Fiber Optic Devices	21
2.4.2.1	Cleaning Connectors	21
2.4.2.2	Cleaning Optical Ports	21

Preface

ABOUT THIS MANUAL

This document provides instructions for installing the Magnum DX40 hardware. This document gives product descriptions, specifications, detailed information on ports and pinouts, all site preparation required to install the product, complete installation procedures, power up instructions, and instructions for removing and maintaining the product. This document is arranged as follows:

[Chapter 1, “Overview”](#) - Contains a brief product description, a list of applicable specifications, and a description of all controls and indicators and pinouts for connectors.

[Chapter 2, “Installation”](#) - Contains all site preparation that must be accomplished prior to installing the DX40, installation in a panel or DIN rail system, powering the unit up, and making all external connections. This chapter also includes maintenance procedures.

CONVENTIONS

Graphically distinctive alerts labeled either “Note” or “Caution” (illustrated below) are interspersed throughout this manual. These alerts call your attention to useful information related to the text immediately following the alert. Notes provide supplemental information or provide a point of emphasis. Cautions warn you of the risk of poor system performance or of system failure.



NOTE: Notes provide you with helpful information about an upcoming step or action. If you do not use the information contained in a Note there is no risk of harm to the system, but using the information will improve performance and/or increase your understanding.



CAUTION: A caution warns you that you should take some action to avoid poor system performance or system failure.



LASER WARNING: This Warning is used to call attention to the fact that Laser output can cause serious damage to the eye.



ELECTRICAL WARNING: This format is used for Electrical Warnings. Callouts of this format are used to notify that a potential of electrocution exists and that a defined action could cause personal injury or death to occur.

RELATED DOCUMENTS

- *Magnum DX Operating Software Administrator’s Guide*

WEB ACCESS

All of the DX40 manuals are also available in .pdf format on the GarrettCom Utility Networks website, www.garrettcomun.com.

YOUR COMMENTS

If you find an error or have a helpful tip on the layout or informational content of this or any other GarrettCom Utility Networks manual please feel free to contact us via email with any problems or helpful information. All enquiries will be responded to with a correction or whatever resolution is required. Please make all comments to support@garrettcom.com or phone a support engineer at 978.688-8807.

Chapter 1

Overview

1.1 Overview

The Magnum DX40 provides connectivity to asynchronous and Ethernet traffic through two programmable serial ports and two Ethernet ports for Fiber optic and (optionally) copper line connections.

1.2 Configuration

The following sections describe the features and requirements of the DX40.

1.2.1 Connectivity

Depending on the DX40 Model ordered, the DX40 is equipped with:

- 2 Ethernet ports,
 - either* 2 100FX multi/single mode SFP
 - or* One 100FX multi/single mode SFP and one 10/100 BaseT, RJ45
- 2 serial programmable RS232/485 ports

These ports are all located on the bottom of the device, along with the MAC address, as illustrated in [Figure 1-1](#).

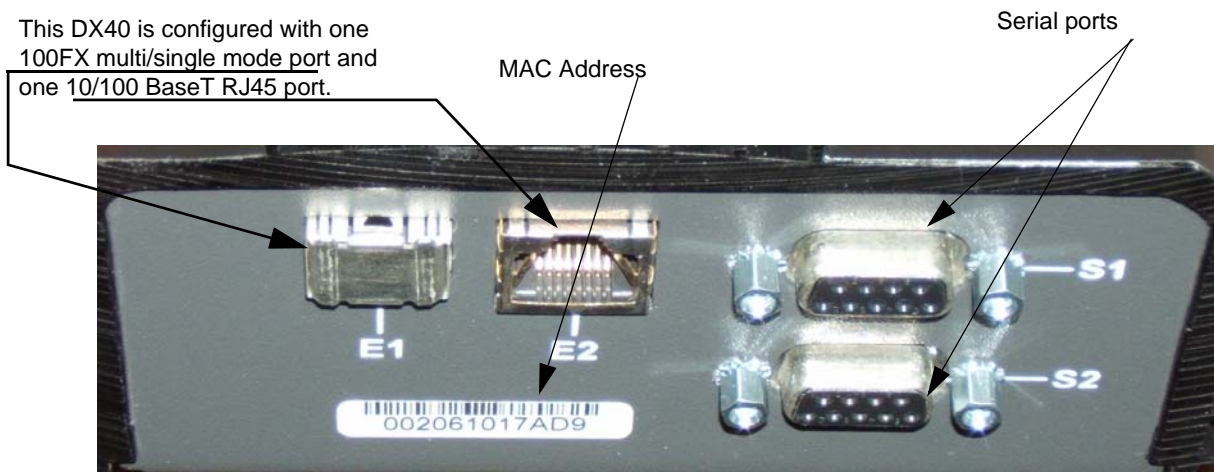
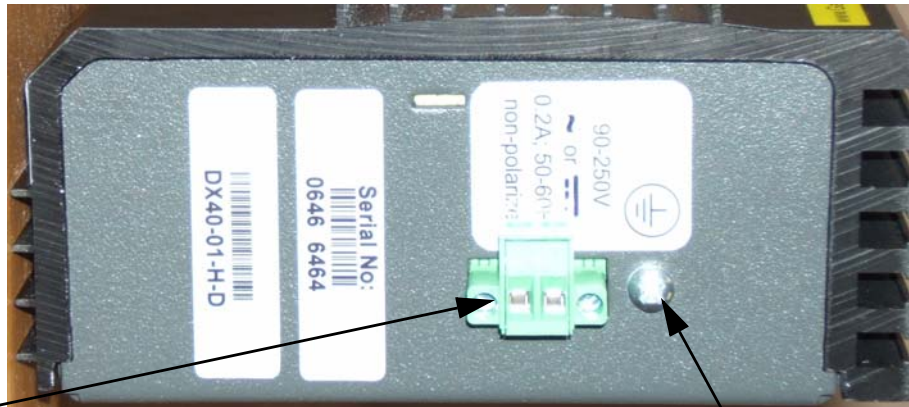

Figure 1-1. Bottom View

1.2.2 Power and Ground

The DX40 can be ordered with a high (90 -250 VAC or VDC) or low (24-48 VDC) voltage power supply. The connection point for the power supply is located at the top of the chassis. The top surface also contains the primary ground stud and labels including serial number, model number, and power specifications, as illustrated in [Figure 1-2](#).

For detailed power specifications see [Table 1-5](#).



2-position Terminal Block Power Connection

Ground Connection

Figure 1-2. Top View

1.2.3 Indicators

The operational status of the ports of the DX40 is indicated by a bank of LEDs on the beveled corner of the chassis, visible from the front and the side, as illustrated in [Figure 1-3](#).

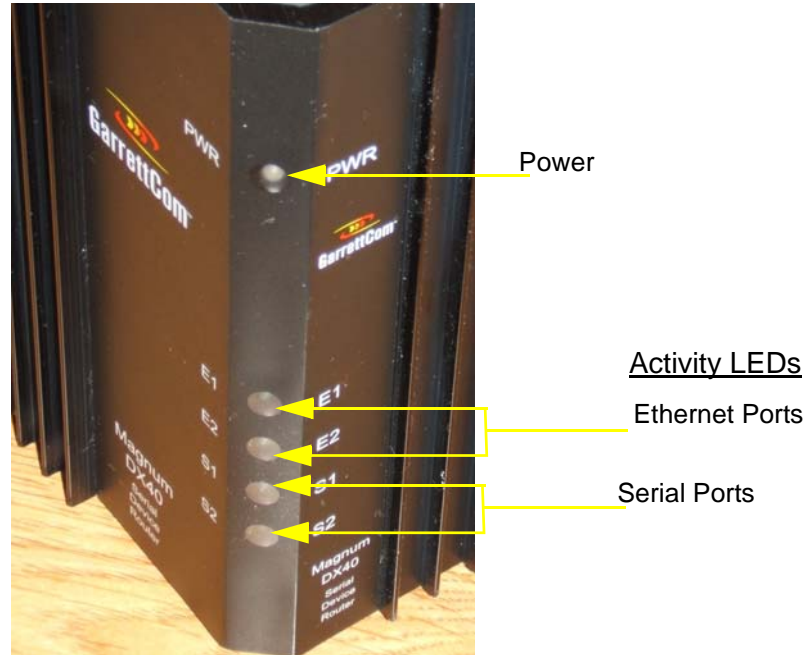

Figure 1-3. Side View

1.2.4 Mounting Options

There are two mounting options for the DX40:

- Panel mount (see [Section 2.3.1.1](#))
- DIN rail mount (see [Section 2.3.1.2](#))

Each of these options requires specific accessory hardware. A DX40 intended for panel mounting is delivered with a pair of panel mounting brackets that fasten to screw holes in the DX40 as illustrated in [Figure 2-2](#). A DX40 intended for DIN rail mounting is delivered with a DIN rail mounting bracket permanently attached.

1.3 Specifications

The following sections provide detailed information about the physical, electronic, and industrial specifications of the DX40.

1.3.1 Physical

The physical dimensions and weight of the DX40 are defined in [Table 1-1](#).

Table 1-1. Physical Specifications

Height:	<ul style="list-style-type: none"> • Chassis only – 5.125 inches (13cm) • Chassis + top and bottom connectors – 6.125 inches (16.56cm)
Width:	5.125 inches (13cm)
Depth:	2.125 inches (5.4cm)
Weight:	3.5 lbs (1.5 kg)

1.3.2 Environmental

The environmental specifications of the DX40 are defined in [Table 1-2](#).

Table 1-2. Environmental Specifications

Operating Temperature:	-40C to 85C (-40F to 185F) No fans
Storage Temperature:	-40C to 85C (-40F to 185F)
Operating Humidity:	95% non-condensing

1.3.3 Optical

The fiber optical specifications of the DX40 are defined in [Table 1-3](#)

Table 1-3. Fiber Optic Specifications

Port Type	Conn. Type	Mode	Tx Power (dBm)		Rx Sensitivity (dBm)		Typical Max, Dist.
			Min.	Max.	Min.	Max.	
100FXPluggableSFP	LC	MM, 1310nM	-19	-14	-32.5	-14	2 km
100FXPluggableSFP	LC	SM, 1310nM	-15	-8	-24	-7	15 km
100FXPluggableSFP	LC	SM, 1310nM	-5	0	-34	-7	40 km

“Typical maximum distance” is an estimated projection based on typical fiber installations; actual distance will depend on actual network attenuation. For all MM (multimode) optics, the recommended fiber cable type is 62.5 / 125 μm fiber. For all SM (single mode) optics, the recommended fiber cable type is 9 μm SM fiber.

1.3.4 Compliance

The industry compliance profile of the DX40 is defined in table [Table 1-4](#).

Table 1-4. Compliance With Standards

Industrial:	IEEE 1613, IEC 61850-3	
Emissions:	EN55022A, FCC Part 15A	
Immunity:	EN55024 EN61000-6-2 EN61000-6-5 EN61000-4-2 (ESD) EN61000-4-3 (RF) EN61000-4-4 (EFT) EN61000-4-5 (SURGE)	EN61000-4-6 (CRF) EN61000-4-10 (MagField) EN61000-4-11 (VDI) EN61000-4-12 (Oscillatory) EN61000-4-16 (CCM) EN61000-4-17 (Ripple) EN61000-4-29 (VDI)
Safety	UL60950, EN60950	

1.3.5 Power Requirements

The power requirements of the DX40 are defined in [Table 1-5](#).

Table 1-5. Power Requirements

	High Voltage AC/DC	Low Voltage DC
Voltage Input Range:	90-250 VAC/VDC	24-48 VDC
Max. Power (Watts):	18	18
Typical Power (Watts):	6	6
Max. Amperage (Amps):	0.2	0.75

1.3.6 Ports and External Connectors

The ports and external connectors of the DX40 are defined in [Table 1-6](#).

Table 1-6. Ports and External Connectors

Port Name	Connector	Description
Ethernet, E1 and E2	LC or LC + RJ45	2 100FX multi/single mode small-format pluggables (SFP) port for fiber optic Ethernet-capable devices or Networks, or one 100FX SFP port and one 10/100 Mbps Ethernet port for connection to copper Ethernet-capable devices.
Serial, S1 and S2	DB9, female	Connection to serial async devices. Configurable to 300, 600, 1200, 2400, 4800, 9600, and 19.2, 28.8, 33.6, 38.4, 57.6, 115.2, 230.4 Kbps.
Power Connection	Terminal block	Non-polarized power input.
Facility Ground Point	Screw	Facility ground connection point.



NOTE: All copper I/O connections must be made with shielded cables and connectors.

1.3.7 Indicators

The status indicators of the DX40 are described in [Table 1-7](#). The operational status of the ports of the DX40 is indicated by a bank of LEDs on the beveled corner of the chassis, visible from the front and the side, as illustrated in [Figure 1-3](#).

Table 1-7. Indicators

LED Name	Condition	Indication
S1 – S2 (Serial Ports)	Green	Port is connected to an active serial device.
	Off	Port is down.
	Flashing	Data is passing through the port.
E1 – E2 (Ethernet Ports)	Green	Port is connected to an active Ethernet device.
	Off	Port is down.
	Flashing	Data is passing through the port.
Power	Green	Normal functioning.
	Off	Power not connected.
	Yellow	Power on but diagnostics not yet run or diagnostics failed.
	Alternating Yellow and Green	Diagnostics in progress.

1.4 Pinouts

The following subsections describe the pinouts of the connectors used with the DX40.

1.4.1 RJ45

Table 1-8 defines the pinout of the RJ45 connector used with the DX40. RJ45 connectors can be used on one of the Ethernet ports for 10/100 BaseT connections to copper Ethernet-capable devices.

Table 1-8. RJ45 Pinout

Pin	Signal
1	Tx +
2	Tx -
3	Rx +
4	not used
5	not used
6	Rx -
7	not used
8	not used

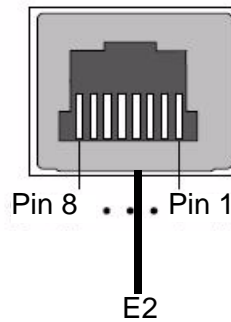

1.4.2 SFP

Table 1-9 defines the pinout of the SFP connector used with the DX40. SFP connectors are used on ports E1 and E2 for 100FX multi/single mode for connections to fiber optic Ethernet-capable devices or networks.

Table 1-9. SFP Pinout

Port	Signal
Tx	Transmit
Rx	Receive

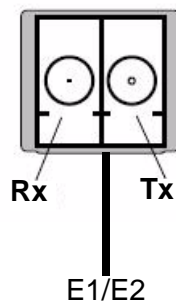

1.4.3 DB9 (Female) – RS232 Serial Ports

Table 1-10 defines the pinout of the DB9 female connector used with serial ports on the DX40 when they are configured for the RS232 interface. DB9 connectors are used on serial ports S1 and S2 for asynchronous or bit-oriented connections.

Table 1-10. DB9 RS232 Pinout

Pin	Name	Dir.	Description
1	DCD	In	Data Carrier Detect from DCE.
2	RXD	In	Receive Data from DCE.
3	TXD	Out	Transmit Data to DCE.
4	DTR	Out	Data Terminal Ready to DCE.
5	GND	Pwr	Signal Ground.
6	DSR	In	Data Set Ready from DCE.
7	RTS	Out	Request To Send.
8	CTS	In	Clear To Send.
9	RI	In	Ring Indicator from DCE.



1.4.4 DB9 (Female) – RS485 Serial Ports

Table 1-11 defines the pinout of the DB9 female connector used with serial ports on the DX40 when they are configured for the RS485 interface.

Table 1-11. DB9 RS485 Pinout

Pin	Signal	Direction
1	RX-	In
2	RX+	In
3	TX-	Out
4	TX+	Out
5	GND	Power
6	Not Used	
7	Not Used	
8	Not Used	
9	Not Used	



Chapter 2

Installation

This chapter provides specific procedures for installing the Magnum DX40, preparing for installation, and uninstalling the device.

2.1 Preparing for Installation

The DX40 is designed to be installed on a DIN rail system or on a panel.

2.1.1 Tools

Regardless of which mounting system you are using, the only tools you will need are screwdrivers: a small slotted screwdriver for the power connector and a medium slotted screwdriver for wall mounting and the grounding screw. (The 6-32 pan head grounding screw will accept both phillips head and slotted screwdrivers.)

The instructions in this manual cover only the physical installation. System configuration is handled through a web-based interface and is described in the *Magnum Network Software – DX Administrator’s Guide*.

2.1.2 Site Suitability

Be sure that your installation site meets the following criteria:

- Conforms with the temperature and humidity ranges detailed in [Table 1-2](#).
- Can meet the power requirements detailed in [Table 1-5](#).
- Will remain stable after the addition of the 3.5 lb. DX40.
- Permits at least two inches of space between the DX40 and any other heat-producing device.

2.1.3 Wiring and Grounding Guidelines

The DX40 requires several different types of connectors, cables, and wires. Requirements and recommendations are listed below:

- Fiber** The fiber cables connected to the DX40 **must** be:
- non-dispersion shifted, single mode (SM)
- or
- multi-mode (MM) fiber cables defined by the Telcordia Technologies General Recommendation 20-CORE standard
- and
- terminated with LC connectors (see [Section 1.3.3.](#))
- Grounding** The primary ground stud located on the top of the chassis **must** be used to connect to an approved ground with a wire meeting the following criteria:
- 14 AWG (minimum)
 - a maximum of five feet in length
 - terminated on the ground lug side with a #6 ring lug
- Facility Power** The facility power cabling attached to the DX40 chassis **must** meet the following criteria:
- cabling constructed using 14 AWG stranded wire
 - cable firmly attached to the terminal holes of the non-polarized power unit, as illustrated in [Figure 2-7.](#)
 - cable routed and strain relieved to the chassis according to good wiring practices
- Copper** Copper I/O cables and connectors must be shielded.

2.1.4 Fiber Optic Safety

Before installing the DX40 you should be aware that devices that employ laser technology, such as the fiber optical SFP ports and associated cabling, can be dangerous. **Do not look directly into a fiber optic port or into the end of a fiber optic line.** Doing so could cause injury to your eye or blindness. Always assume that there is laser activity in the line or port, even if the device is powered down. As a reminder, whenever this manual calls for the handling of fiber optic lines, those instructions will be accompanied by a “Laser Warning,” as follows:



LASER WARNING: DO NOT LOOK INTO A FIBER OPTIC CABLE OR PORT! These can produce invisible light that may do serious eye damage. Always assume that fiber optic cables or ports are actively radiating light energy.

2.1.5 Fiber Optic Handling

Contamination from dust, dirt, oils from the hands and other sources can impede the transmission and reception of optical signals through the optical fibers. When handling the optical connectors and fiber cables, follow these precautions to minimize the contamination of the connectors and ports:

- Cover optical connectors and ports with dust caps when they are not in use.
- Do not touch fiber tips or the interior of optical ports when handling fiber cables and connectors.
- Clean fiber optic connectors as described in [Section 2.4.2.1, “Cleaning Connectors”](#) prior to making any optical connection.
- Clean optical ports as described in [Section 2.4.2.2, “Cleaning Optical Ports”](#) if contaminants or degraded performance are noted on the interface.

Fiber optic connectors should be cleaned after each use and optical ports should be cleaned if you notice contamination or degraded performance.

Fiber optic cables and connectors are fragile and can be easily broken through rough handling. When handling fiber optic media, take the following precautions:

- Do not strike the fiber cable with tools.
- Do not pinch, crimp, or compress the jacketing of the optical cable.
- Do not use less than the minimum bend radius of 3 inches (7.62 cm) when routing or coiling cables.

2.1.6 External Connections

You can speed up the installation of the DX40 by having the following equipment and information on hand before beginning:

- A supply of cables and connectors of the required types.
- IP addresses for new devices and any existing devices you will be connecting to.
- Your notes on naming conventions and end point information.

2.2 Unpacking

Unpack and inspect the DX40.

The DX40 is shipped with the following items in the box:

- DX40 unit
- Appropriate mounting brackets: for DIN rail applications the DIN mounting bracket is permanently attached with rivets; for panel mounting two brackets are attached with screws
- Document CD-ROM
- Optionally, Ethernet cable - RJ45 terminations, 10' long
- Optionally, two fiber optic SFPs

Be sure that all the equipment you have ordered is included in the shipment.

Remove the unit from the styrofoam end caps and inspect the DX40 chassis for dents or other shipping related damage. Report any damage immediately to GarrettCom Utility Networks customer support and DO NOT INSTALL the unit.

2.2.1 Attaching Optional Ethernet Fiber Optic SFPs

The SFPs are optional equipment for the DX40. Depending on the specifics of your order these might have been installed at the factory. It is also possible that you have ordered them separately from GarrettCom or from another manufacturer. If this is the case, before proceeding with mounting the unit and making cable connections, you must install the SFPs in Ethernet ports E1 and/or E2.



ELECTRICAL WARNING: SFPs are static-sensitive devices. Failure to handle these devices properly can cause premature failure. Follow proper static safe handling precautions (such as the use of static safe wrist straps) when working with SFPs.

All SFPs must conform to industry standards and they share a similar appearance.

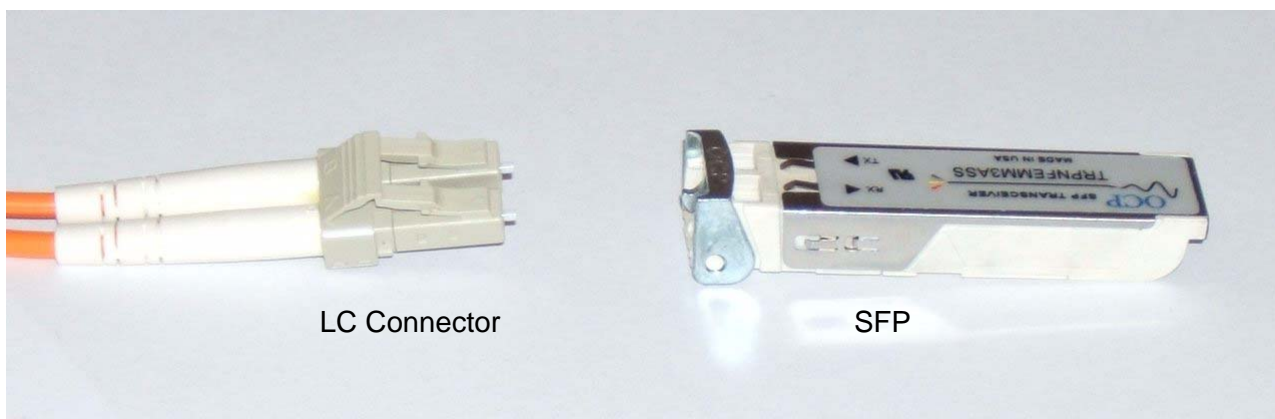

Figure 2-1. SFP and LC connector

To install an SFP in port E1 or E2:

1. Slide the SFP into the Ethernet port until it is firmly seated.
2. Attach the protective cap to avoid contamination until you are ready to attach cable.

2.3 Installation of the DX40 Unit

To install the DX40 you must first

- Mount it
- Make the ground and power connections.
- Connect the network cables

2.3.1 Mounting

Your DX40 shipment includes the mounting hardware you have ordered as appropriate to your site. This hardware is one of:

- A pair of 2" brackets for mounting on a panel.
- A DIN rail mounting bracket permanently attached to the chassis.

2.3.1.1 Mounting on a Panel

Each bracket for mounting on a panel is attached with two screws to the rear surface of the DX40. [Figure 2-2](#) illustrates the DX40 with panel mounting brackets in place.

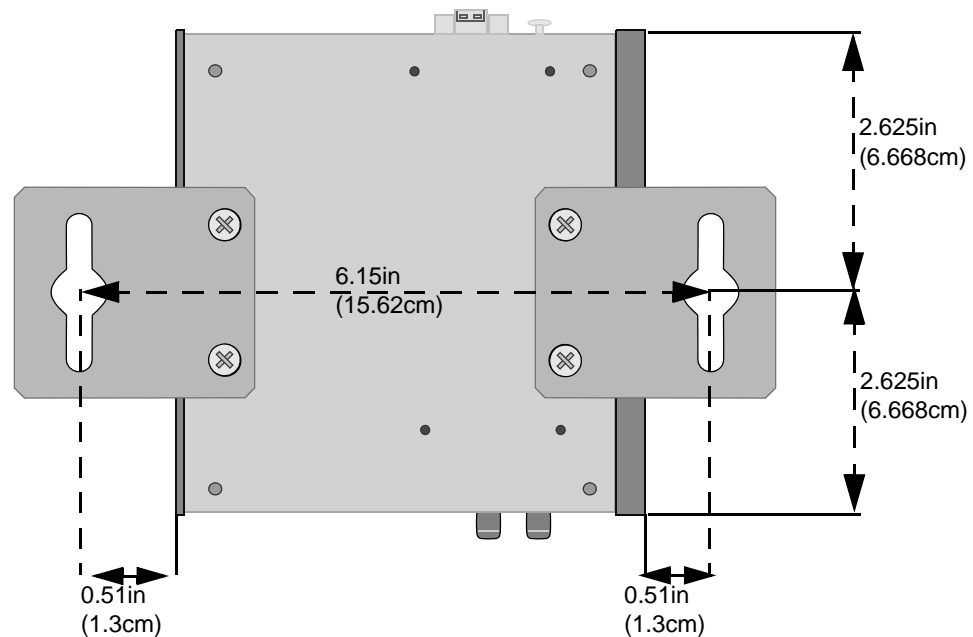

Figure 2-2. DX40 configured for Panel Mounting

2.3.1.2 Mounting in a DIN Rail System

The DIN rail bracket is attached with rivets to the narrow surface of the DX40 opposite the LED display. The bracket attaches to the DIN rail by means of a pair of stationary prongs near the top of the bracket and a single spring-loaded prong (the release mechanism) toward the bottom of the bracket.

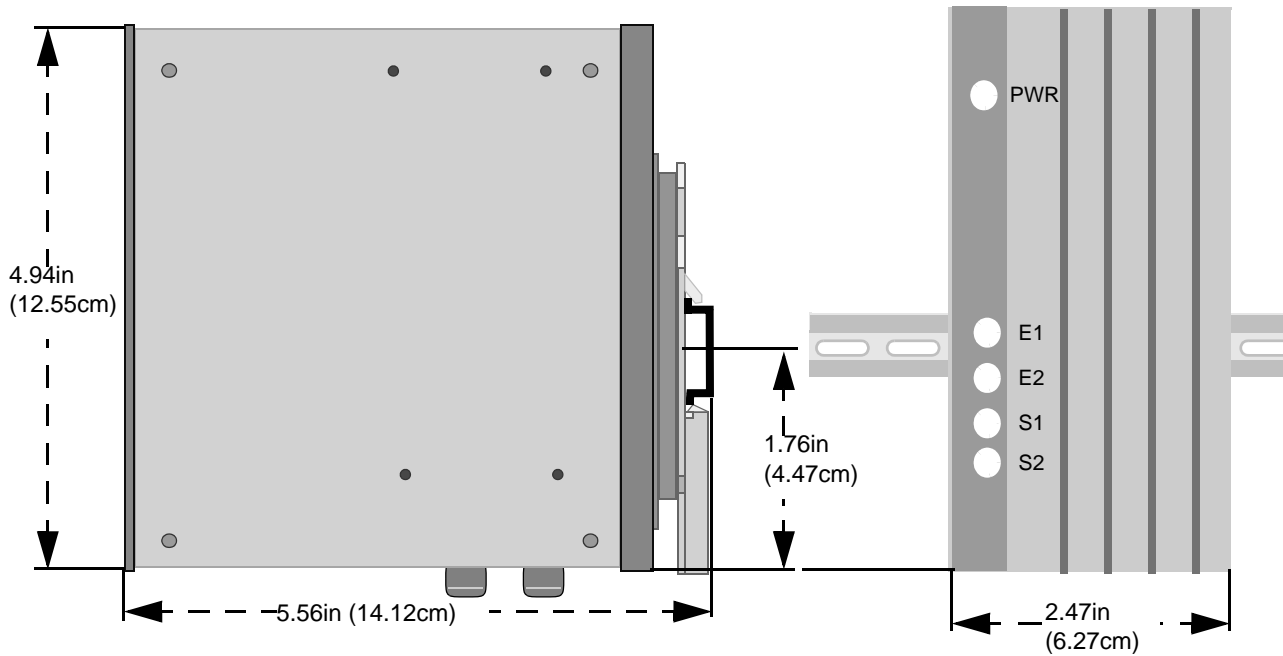

Figure 2-3. DX40 configured for DIN Rail Mounting

To fasten the DX40 into a DIN rail system begin by slipping the upper pair of prongs over the top of the rail. Then, while depressing the spring-loaded release mechanism (as illustrated in [Figure 2-4](#)), press the DX40 flush against the DIN rail and remove the screwdriver to allow the release mechanism to close. Check to make sure that the top and bottom prongs on the bracket are securely attached to the DIN rail.

When the DX40 is fastened into the DIN rail system it can be released by downward pressure on the release mechanism. To unmount the DX40 insert the tip of a screwdriver into the slot in the metal “tail” that projects below the DX40 chassis and force the release mechanism down (see [Figure 2-4](#)). Take care not to apply pressure to any I/O connector or SFP transceiver.

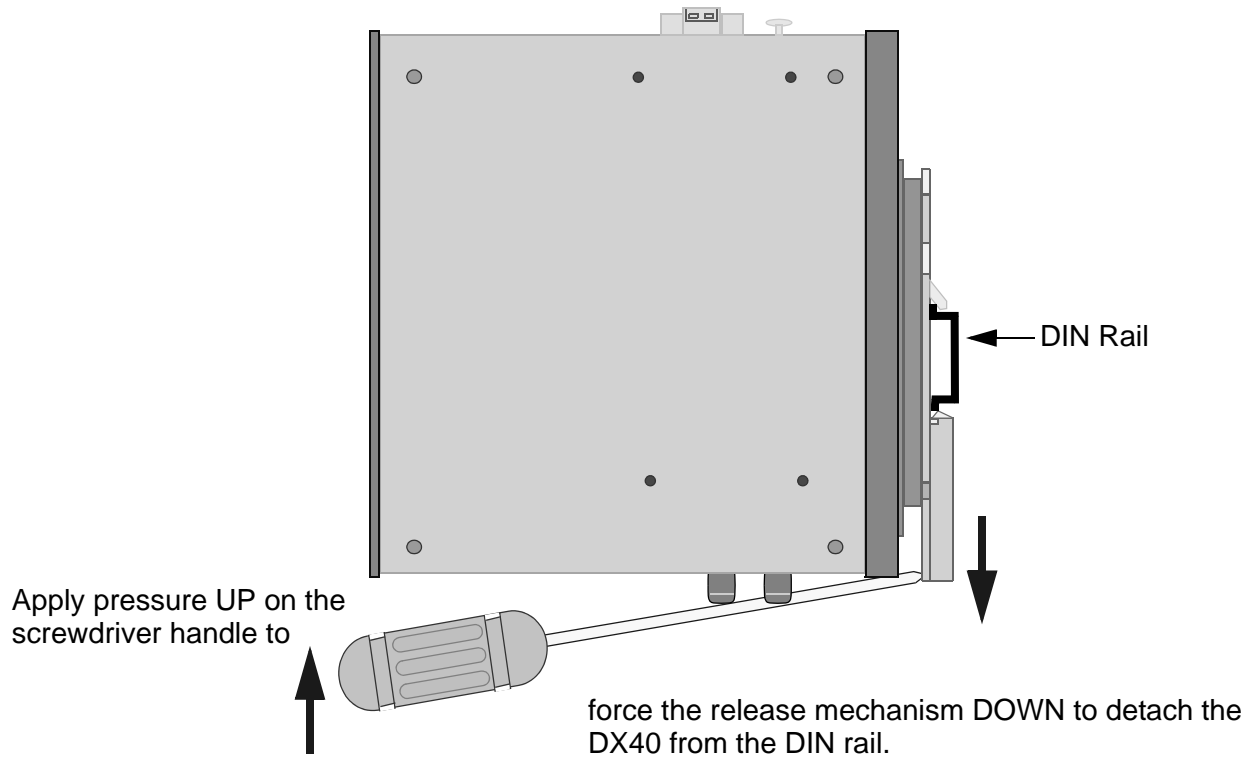

Figure 2-4. Unmounting from a DIN Rail System

2.3.2 Connecting Facility Power

The DX40 comes in either high or low voltage models. The unit does not have a power on/off switch and is active when the power is connected.



ELECTRICAL WARNING: Always ensure that the ground connection is made prior to connecting facility power to the DX40. The ground provides a protective circuit connection to ground in cases of transients and power surges. Connect the facility power to a DC or AC unit as described in the following sections.

2.3.2.1 Making the Ground and Power Connections

The DX40 provides a hardened DC or AC power supply for industrial applications and/or hostile environments. The grounding screw and power supply connector are located on the top of the unit as shown in [Figure 2-5](#).

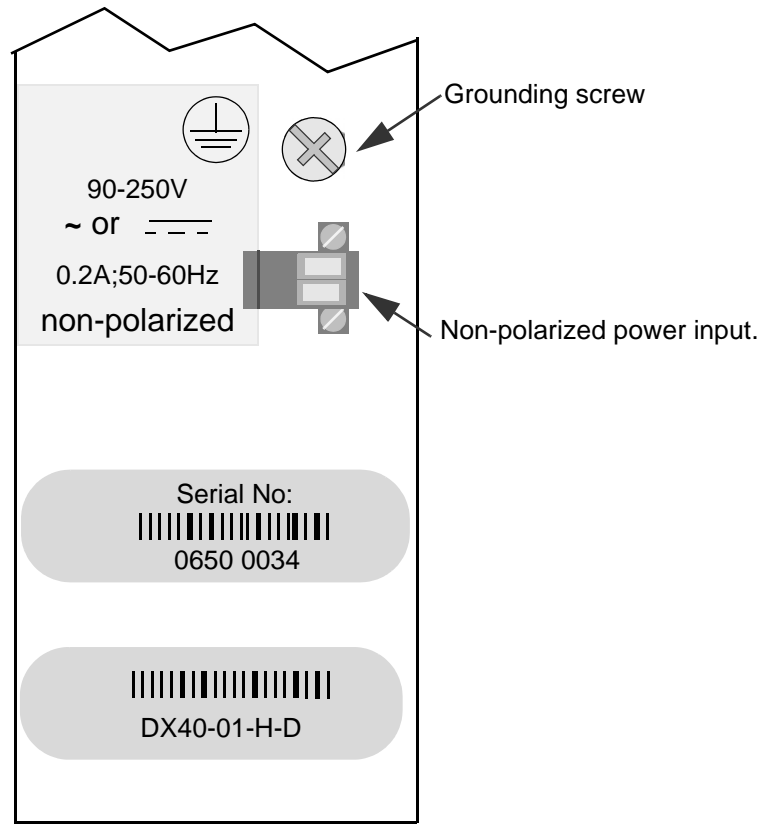

Figure 2-5. Ground and Power Connections



ELECTRICAL WARNING: Verify that a proper ground connection is made from the grounding screw to facility ground prior to connecting power to the DX40. Failure to have a proper ground path could cause serious injury or death to personnel in cases of power surges.

Making the Ground Connection

The ground wire should be 14 AWG terminated with a #6 ring lug.

Make the facility ground connection as follows:

1. Loosen the ground screw on the chassis, insert the #6 ring lug, and tighten the ground screw.
2. Connect the other end of the ground wire to the facility ground.

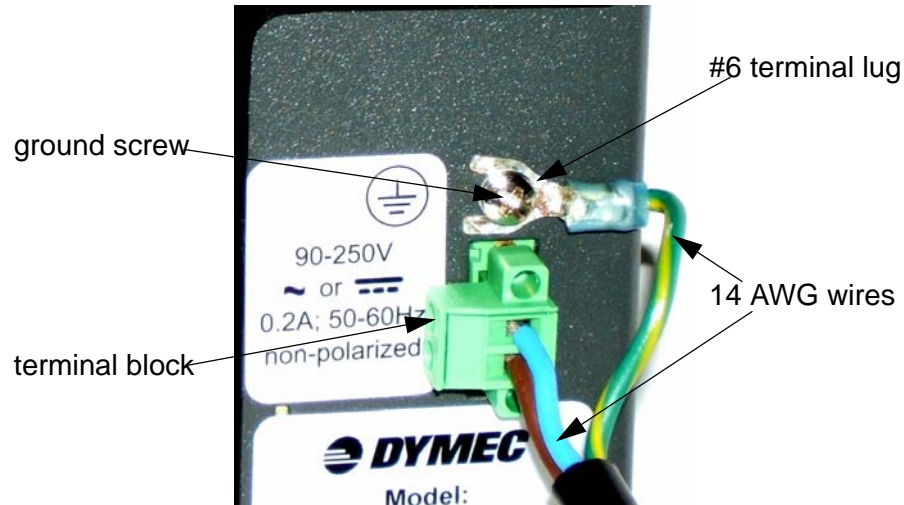

Figure 2-6. Power and Ground Properly Connected

Making the Power Connection

The power wires should be 14 AWG. Smaller wires may be used, down to 18 AWG, but verify that they meet your local electrical requirements.

Connect the power to the unit as follows.



ELECTRICAL WARNING: Ensure that power is disconnected from wiring prior to handling! Check the voltage rating next to the power connector - verify that it matches the power source.

1. Remove the plug portion of the power connector by loosening the two captive mounting screws.
2. Strip back 1/4" off the insulation of the wires that will connect the unit to the power source.
3. Loosen saddle screw and insert each conductor firmly into a terminal hole of the plug (**note: this connection is not polarity sensitive.**)
4. Visually inspect that no strands of wire are straying out of the hole, potentially shorting to ground or the other conductor. Tighten the saddle screws until the wires are secure.
5. Re-insert the plug into the power connector and secure the two captive mounting screws.

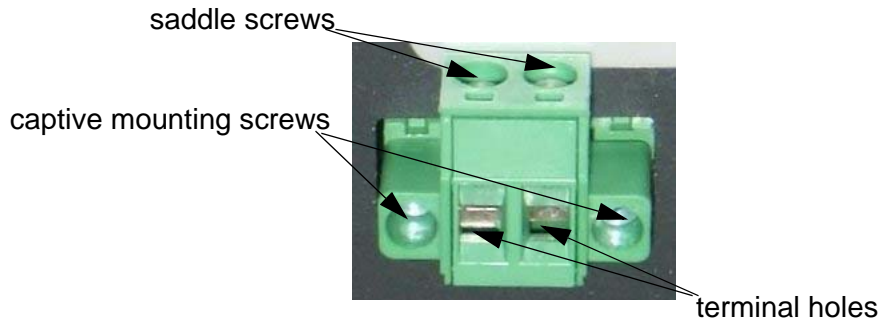

Figure 2-7. Non-Polarized Power Input

2.3.3 Connecting Network Cables

There are three types of connections that can be made to the DX40. They are serial, Ethernet copper, and Ethernet fiber optic. The following sections describe each type of connection separately.

2.3.3.1 Connecting Serial Cables

This procedure assumes that one end of the Serial device cable is already attached to the end unit. Be aware of the serial port numbering scheme when installing the cables (see **Figure 1-1 on page 1**). The ports are configured in software later on and if a device is accidentally connected to the wrong port it will be difficult to detect.

Connect cables to the Serial ports as described below:

1. Align the DB9 connector with appropriate serial port and push gently until the connector is completely mated to the port.
2. Tighten the two extended capture screws hand tight.
3. Make sure that the connector is not supporting the whole weight of the cable. Providing strain relief on these cables will ensure a stable connection.
4. Return to step one above and connect the remainder of the serial cables.

2.3.3.2 Connecting Ethernet Copper Cables

If your DX40 is configured with port E2 as a standard RJ45 port, connect a shielded Ethernet cable to the Ethernet port as follows.(see **Figure 1-1 on page 1**).

1. Install the RJ45 connector into the port with the clip facing up.
2. Push the RJ45 connector into the slot until you hear a click.
3. Give the cable a gentle tug to ensure that the connector clip is firmly seated.
4. Verify that the connection has been made by checking the LED associated with this port on the DX40 chassis. It should be illuminated. If the link LED is not illuminated verify that the equipment on the other end of the cable is powered up and properly connected.

2.3.3.3 Connecting Fiber Ethernet Cables

Ports E1 (and, optionally, E2) can be configured with SFPs to support fiber optic connections. These ports accept LC type connectors. The procedure for installing these connectors is given in [Section 2.2.1, "Attaching Optional Ethernet Fiber Optic SFPs"](#).

Follow the fiber optic safety precautions and steps to install the fiber optic cables to these ports and refer to [Figure 1-1](#) for Ethernet port locations.



LASER WARNING: DO NOT LOOK INTO A FIBER OPTIC CABLE OR PORT! These can produce invisible light that may do serious eye damage. Always assume that fiber optic cables or ports are actively radiating light energy.

Connect cables to the fiber optic ports as described below:

1. Remove the dust cap from the optical port and from the fiber cable end.
2. Inspect the cable end and the port for contamination. If any contamination is found clean the port or cable according to [Section 2.4.2, "Cleaning Fiber Optic Devices"](#).
3. Insert the fiber cable connector into the fiber port. Listen for the click that signifies the connector is properly seated.
4. Give the cable a gentle tug to make sure it is securely installed.
5. Ensure that the cables are properly secured and do not hang freely. Excessive bending could cause damage to the fiber strand.
6. Return to step one above and connect the remainder of the cables.

2.4 Maintenance

The DX40 is designed to be replaced as a unit. There are no servicing requirements and there are no user-repairable components in this device. Maintenance is limited to replacing the unit and cleaning any fiber optic connectors and ports.

The following sections detail disconnecting all connections to the chassis, removing the chassis, cleaning optical devices and packing the DX40 for return to the manufacturer. If it is still possible to connect a terminal to the malfunctioning DX40 and retrieve any configuration data from the device, do so prior to removing power.

2.4.1 Removing the DX40

Removing the DX40 entails disconnecting the network cabling, disconnecting the power lines and ground lines, and removing the chassis from the rack or other installation location. The unit can then be packed for shipment to the manufacturer.

2.4.1.1 Disconnecting Network Cables

The sequence for removal of the serial and Ethernet cables is not important, but it is important to note that there are active devices connected to each end of the cable.

1. Remove all of the Async DB9 connectors from the serial ports by unscrewing the two captive screws on each cable and pulling the connector off the port. (Label the connector with the port number if the cable is to be reconnected at some later time.)
2. Remove the Ethernet RJ45 connectors from the Ethernet ports by pressing on the clip on the underside of the modular connector and pulling the connector straight out. (Label the connector with the port number if the cable is to be reconnected at some later time.)



LASER WARNING: DO NOT LOOK INTO A FIBER OPTIC CABLE OR PORT! These can produce invisible light that may do serious eye damage. Always assume that fiber optic cables or ports are actively radiating light energy.

3. Following the safe handling procedures for fiber optic cables and connectors, remove any fiber optic cable connected to the Ethernet fiber ports. Immediately install dust caps on the cable end and the fiber port. (Label the connector with the port number if the cable is to be reconnected at some later time.)

2.4.1.2 Disconnecting Power and Ground Lines



ELECTRICAL WARNING: Before disconnecting either AC or DC power connections at the DX40 ensure that the facility power has first been turned off. Failure to shut power off prior to removing the power connections could expose you to dangerous voltages causing injury or death.

Follow the procedure below to disconnect the power and ground lines.

1. Verify that power to the DX40 is turned off.
2. Use a screw driver to loosen the two screws that tighten the wire clamps in the non-polarized power connector. Remove the wires from the connector.



ELECTRICAL WARNING: If the wires are not to be used immediately properly insulate them to ensure that an accidental turning on of the power will not cause a short or electrical hazard.

3. Remove the ground wire from the chassis by loosening the grounding screw.

2.4.1.3 Packing the DX40 for Shipment

If you have saved the shipping box that your DX40 was received in then add the end styrofoam pieces around the chassis and place the unit in the box. Please contact customer support to receive a valid RMA number so that this item is either repaired and returned or credited to your account. Products without a proper RMA number will not be accepted for repair by GarrettCom Utility Networks.

If you have not saved the original shipping container then place the unit in a box so that normal shipping activities will not cause any damage to the unit. GarrettCom Utility Networks has no responsibility for the product during return shipping. For more warranty information, see [“Warranty” on page ii](#), and for details for the requirements for returning equipment, see [“Return Of Equipment” on page iii](#).

2.4.2 Cleaning Fiber Optic Devices

This section covers the cleaning requirements and procedures for the fiber optic cable connectors and the optical ports on the DX40. Clean the connectors after each use and the optical ports when contamination is suspected or there is a performance degradation which may be attributable to contamination. All fiber optic connectors and optical ports should be capped with dust caps when not in use.

The cleaning materials used should be rated for fiber optic devices. Specifically cloth, wipes and swabs should be lint-free, non-abrasive and free of additives. Cleaning fluids should be restricted to optical-grade isopropyl alcohol. Canned (compressed) air should be used to blow out dust and particulate matter and to dry residual isopropyl alcohol after cleaning.

2.4.2.1 Cleaning Connectors

These instructions are recommended each time a fiber optic connector is used. Clean the fiber optic connectors as follows:

1. Blow out any dust or particulate matter from the connector end, using canned air.
2. Wipe out the connector end surfaces with a cloth or pad saturated in isopropyl alcohol.
3. Blow dry the connector surfaces, using canned air, by directing the air flow across the tip but not directly down onto the tip.
4. Using care not to touch the fiber tip, install a dust cap or connect to an optical port.

2.4.2.2 Cleaning Optical Ports

These instructions are recommended only when there is evidence of contamination or when reduced performance has been detected. Clean the optical ports as follows:

1. If required, remove the fiber optic connector from the optical port and clean the connector as described in “Cleaning Connectors,” above.
2. Insert the extension tube, supplied with the canned air, into the canned air nozzle and blow out the optical port. Use care not to touch the bottom of the optical port.
3. Reconnect the fiber optic connector removed in step 1.

If degraded performance persists, perform the following additional steps:

- 4.** Remove the fiber optic connector and place a dust cap on the end.
- 5.** Using a small-head, lint-free swab gently wipe out the optical port. Repeat steps 2 and 3.