



NETWORKS FOR INDUSTRY

# ***DynaStar 1500***

## ***Installation***

***and***

## ***Maintenance***

## ***Guide***

**Dymec, Inc.**  
25 Commerce Way #1  
North Andover, MA 01845  
Phone: 978.688.8807  
Fax: 978.688.8771



---

---

# DECLARATIONS

---

---

## DOCUMENT NOTICE

### Copyright

Copyright 2006 by Dymec, Inc. Printed in the US. All rights reserved.

This manual may not be reproduced or disclosed in whole or in part by any means without the written consent of Dymec, Inc. DYNASTAR is a trademark of Dymec, Inc. All other trademarks mentioned in this document are the property of their respective owners.

This document has been prepared to assist users of equipment manufactured by Dymec, Inc., and changes are made periodically to the information in this manual. Such changes are published in Software Release Notices. If you have recently upgraded your software, carefully note those areas where new commands or procedures have been added. The material contained in this manual is supplied without any warranty of any kind. Dymec, Inc. therefore assumes no responsibility and shall incur no liability arising from the supplying or use of this document or the material contained in it.

### Rights

Except as set forth in the Software License Agreement, Dymec, Inc. makes no representation that software programs and practices described herein will not infringe on existing or future patent rights, copyrights, trademarks, trade secrets or other proprietary rights of third parties and Dymec, Inc. makes no warranties of any kind, either express or implied, and expressly disclaims any such warranties, including but not limited to any implied warranties of merchantability or fitness for a particular purpose and any warranties of non-infringement. The descriptions contained herein do not imply the granting of licenses to make, use, sell, license or otherwise transfer Dymec, Inc. products described herein. Dymec, Inc. disclaims responsibility for errors which may appear in this document, and it reserves the right, in its sole discretion and without notice, to make substitutions and modifications in the products and practices described in this document.

### Part Number Information

Paper Version Part Number: 3-01-0080-01 Rev AD

CD Part Number: 3-01-0080-02 Rev AF

### Revision History

Release Date	Document Revision	Software Release	Change Note
Feb 2006	AC	7.3	Software upgrade to 7.3, addition of RS485 interface
Oct 2006	AD	7.3	Corrected pinout in Table 1-8

## WARRANTY

DYMEC, Inc. warrants equipment manufactured by it to be free from defects in materials and workmanship for a period of one (1) year from date of shipment. If within the warranty period the purchaser discovers such item was not as warranted above and promptly notifies DYMEC, Inc. in writing, DYMEC, Inc. shall repair or replace the items at the company's option. This warranty shall not apply to: (a) equipment not manufactured by DYMEC, Inc.; (b) equipment which shall have been repaired or altered by anyone other than DYMEC, Inc.; (c) equipment which shall have been subjected to negligence, accident, or damage by circumstances beyond DYMEC, Inc. control, or to improper operation, maintenance or storage, or to other than normal use or service. With respect to equipment sold but not manufactured by DYMEC, Inc., the warranty obligation of DYMEC, Inc. shall, in all aspects, conform and be limited to the warranty actually extended to DYMEC, Inc. by its supplier.

The foregoing warranties do not cover reimbursement for labor, transportation, removal, installation, or other expenses that may be incurred in connection with repair or replacement.

**THE FOREGOING WARRANTIES ARE EXCLUSIVE AND IN LIEU OF ALL OTHER EXPRESS AND IMPLIED WARRANTIES EXCEPT WARRANTIES OF TITLE, INCLUDING, BUT NOT LIMITED TO, IMPLIED WARRANTIES OF MERCHANTABILITY AND FITNESS FOR A PARTICULAR PURPOSE.**

## LIMITATION OF LIABILITY

Anything to the contrary herein contained notwithstanding, **DYMEC, INC., ITS CONTRACTORS AND SUPPLIERS OF ANY TIER, SHALL NOT BE LIABLE IN CONTRACT, IN TORT (INCLUDING NEGLIGENCE OR STRICT LIABILITY) OR OTHERWISE FOR ANY SPECIAL, INDIRECT, INCIDENTAL OR CONSEQUENTIAL DAMAGES WHATSOEVER.** The remedies of the purchaser set forth herein are exclusive where so stated and the total cumulative liability of DYMEC, Inc. its contractors and suppliers of any tier, with respect to this contract or anything done in connection therewith, such as the use of any product covered by or furnished under the contract, whether in contract, in tort (including negligence or strict liability) or otherwise, shall not exceed the price of the product or part on which such liability is based.

Unless otherwise agreed to in writing by an authorized official of DYMEC, Inc., products sold hereunder are not intended for use in or in connection with a nuclear facility or activity. If so used, DYMEC, Inc. disclaims all liability for nuclear damage, injury or contamination, and purchaser shall indemnify DYMEC, Inc. against any such liability, whether as a result of breach of contract, warranty, tort (including negligence) or otherwise.

## PATENTS

As to equipment proposed and furnished by DYMEC, Inc., DYMEC, Inc. shall defend any suit or proceeding brought against purchaser so far as based on a claim that said equipment constitutes an infringement of any patent of the United States, if notified promptly in writing and given authority, information, and assistance at DYMEC, Inc.'s expense for the defense of the claim. In event of a final award of costs and damages from such a suit, DYMEC, Inc. shall pay such award. In event the use of said equipment by purchaser is enjoined in such a suit, DYMEC, Inc. shall, at its own expense, and at its sole option either (a) procure for purchaser the right to continue using equipment, (b) modify said equipment to render it non-infringing, (c) replace said equipment with non-infringing equipment, or (d) refund the purchase price (less depreciation) and transportation and installation costs of said equipment. DYMEC, Inc. will not be responsible for any compromise or settlement made without its written consent. The foregoing states the entire liability of DYMEC, Inc. for patent infringement, and in no event shall DYMEC, Inc. be liable if the infringement charge is based on the use of DYMEC, Inc. equipment for a purpose other than that for which it was sold by DYMEC, Inc. As to any equipment furnished by DYMEC, Inc. to purchaser and manufactured in accordance with designs proposed by purchaser, purchaser shall indemnify DYMEC, Inc. against any award made against DYMEC, Inc. for patent, trademark, or copyright infringement.

## RETURN OF EQUIPMENT

**No equipment may be returned without purchaser first obtaining DYMEC, Inc.'s written Return Material Authorization (RMA).**

Equipment accepted for credit, not involving a DYMEC, Inc. error, shall be subject to all the terms of the original purchase contract and to a service charge of 20% of the invoice price. Returned equipment must be of current manufacture, unused, and in reasonable condition, securely packed to reach DYMEC, Inc. without damage, shipped F.O.B. DYMEC, Inc. facility with transportation charges paid, and labeled with Return Material Authorization (RMA) number. Any cost incurred by DYMEC, Inc. to put equipment in first class condition will be charged to purchaser.

## COMPLIANCE NOTICES

### FCC Part 15

This device complies with part 15 of the FCC Rules. Operation is subject to the following two conditions: (1) This device may not cause harmful interference, and (2) this device must accept any interference received, including interference that may cause undesired operation.

Note: This equipment has been tested and found to comply with the limits for a Class A digital device, pursuant to part 15 of the FCC Rules. These limits are designed to provide reasonable protection against harmful interference when the equipment is operated in a commercial environment. This equipment generates, uses and can radiate radio frequency energy and, if not installed and used in accordance with the instruction manual, may cause harmful interference to radio communications. Operation of this equipment in a residential area is likely to cause harmful interference in which case the user will be required to correct the interference at his/her own expense.

Changes or modifications could void the user's authority to operate the equipment. The user is cautioned not to change or modify this product.

## **DECLARATIONS**

### *Safety*

---

### **ACTA TIA/EIA IS-968A (Formerly FCC Part 68)**

This equipment complies with ACTA TIA/EIA IS-968A rules. On the device is a label that contains, among other information, the FCC registration number for this equipment. If requested, this information must be provided to the telephone company. (Note: REN [Ringer Equivalence Number] does not apply to this equipment.)

The telephone company may make changes in its facilities, equipment, operations, or procedures that could affect the operation of this equipment. If this happens, the telephone company will provide advance notice in order for you to make necessary modifications to maintain uninterrupted service.

### **IC CS03 (Industry Canada)**

This digital apparatus does not exceed the Class A limits for radio noise emissions from digital apparatus set out in the interference-causing equipment entitled “Digital Apparatus”, ICES-003 of the department of Communications (Cet appareil numérique respecte les limites bruits radioélectriques applicables aux appareils numériques de Class A prescrites dans la norme sur le matériel brouilleur: “Appareils Numériques”, NMB-003 édictée par le ministre des Communications).

### **EN55022**

Warning: This is a Class A product. In a domestic environment this product may cause radio interference, in which case the user may be required to take adequate measures.

## **SAFETY**

**WARNING:** Service to this unit can be made only by factory authorized personnel. Failure to observe this caution can result in malfunction to the unit as well as electrocution to personnel.

**Avertissement:** Cet appareil ne peut être examiné ou réparé que par un employé autorisé du fabricant. Si cette consigne n’est pas respectée, il y a risque de panne et d’électrocution.

**Vorsicht:** Dieses Gerät darf nur durch das bevollmächtigte Kundendienstpersonal der fabrik instandgehalten werden. Die Nichtbeachtung dieser Vorschrift kann zu Fehlfunktionen des Gerätes führen und das Personal durch Stromschläge gefährden.

Industry Canada Warnings	Avis d'Industrie Canada
<p>Notice:</p> <p>Before installing this equipment, users should ensure that it is permissible to be connected to the facilities of the local telecommunications company. The equipment must also be installed using an acceptable method of connection. The customer should be aware that compliance with the above conditions may not prevent degradation of service in some situations.</p> <p>Repairs to certified equipment should be coordinated by a representative designated by the supplier. Any repairs or alterations made by the user to this equipment, or equipment malfunctions, may give the telecommunications company cause to request the user to disconnect the equipment.</p>	<p>Avis:</p> <p>Avant d'installer ce matériel, l'utilisateur doit s'assurer qu'il est permis de le raccorder aux installations de l'entreprise locale de télécommunication. Le matériel doit également être installé en suivant une méthode acceptée de raccordement. L'abonné ne doit pas oublier qu'il est possible que la conformité aux conditions énoncées ci-dessus n'empêche pas la dégradation du service dans certaines situations.</p> <p>Les réparations de matériel homologué doivent être coordonnées par un représentant désigné par le fournisseur. L'entreprise de télécommunications peut demander à l'utilisateur de débrancher un appareil à la suite de réparations ou de modifications effectuées par l'utilisateur ou à cause de mauvais fonctionnement.</p>
<p>Users should ensure for their own protection that the electrical ground connections of the power utility, telephone lines, and internal metallic water pipe system, if present, are connected together. The precaution may be particularly important in rural areas.</p>	<p>Pour sa propre protection, l'utilisateur doit s'assurer que tous les fils de mise à la terre de la source d'énergie électrique, des lignes téléphoniques et des canalisations d'eau métalliques, s'il y en a, sont raccordés ensemble. Cette précaution est particulièrement importante dans les régions rurales.</p>

## Class 1 Laser Products

The **DYNASTAR 1500** may use 100 FX SFP Ethernet Class 1 Laser products. Read the following safety information before installing or operating these devices. The transmitter output is factory set, and does not allow any user adjustment. Class 1 Laser products comply with the following safety standards:

- 21 CFR 1040.10 and 1040.11 U.S. Department of Health and Human Services (FDA)
- IEC Publication 60825-1: 1998 (International Electrotechnical Commission)

When operating within their performance limitations, the laser transmitter output meets the Class 1 accessible emission limit of both standards. Class 1 levels of laser radiation are not considered hazardous.



**LASER WARNING:** Laser output can cause serious damage to the eye. The lasers used in the **DYNASTAR 1500** produce light that is invisible to the naked eye. It must be assumed at all times that the fiber optic cables and optical ports are radiating light energy. When connecting or handling the fiber cables or connectors, it is imperative that the technician avoid looking into the tip of the fiber.

## Laser Radiation and Connectors

When the connector is in place, all laser radiation remains within the fiber. Removing the optical connector from the transmitter allows laser radiation to emit directly from the optical port.

Do not use optical instruments to view the laser output. The use of optical instruments to view laser output increases eye hazard. When viewing the output optical port, power must be removed from the **DYNASTAR 1500**.

## **DECLARATIONS**

*Contacting Dymec*

---

### **Service Personnel Warning**

The **DYNASTAR 1500** may be AC or DC powered. Remove all power connections at the circuit panel before removing the unit.

The installation of this product must comply with all applicable codes and practices specified by the country, city, and operating company in which it is installed.

### **Conformité UL (E.-U. et Canada)**

Dans le cas des unités devant fonctionner sous 120 V c.a., utilisez un cordon d'alimentation homologue UL constitué au minimum d'un cordon de calibre 14 AWG (0,83 mm<sup>3</sup>) de type SVT ou SJT à trois conducteurs d'une longueur maximale de 15 pieds muni d'une prise à lames parallèles avec mise à la terre et pouvant supporter 15 A à 125 V. Dans le cas des unités devant fonctionner sous 250 V c.a. conformément aux normes internationales, utilisez un cordon d'alimentation homologue UL constitué au minimum d'un cordon de calibre 14 AWG (0,83 mm<sup>3</sup>) muni d'une prise avec mise à la terre pouvant supporter 15 A à 240 V, marqué HAR et conforme aux normes de sécurité en vigueur dans le pays où le matériel doit être utilisé.

### **Grounding**

This equipment is equipped with an external grounding bolt (#10/32 UNF-2B). All units requiring grounding, use a grounding wire a minimum size of 14 AWG at a maximum length of five feet. The ground lug bolt should be torqued to 32 inch pounds.

## **CONTACTING DYMEC**

By Mail:

Dymec, Inc.  
25 Commerce Way #1  
North Andover, MA 01845

Telephone:

978.688-8807

Fax:

978.688-8771

Website:

[www.dymec.com](http://www.dymec.com)

Email:

[support@dymec.com](mailto:support@dymec.com)

Customer support representatives are available during normal business hours, 8 - 5pm EST.

---

---

# TABLE OF CONTENTS

---

---

## DECLARATIONS

Document Notice .....	i
Copyright .....	i
Rights .....	i
Part Number Information .....	i
Revision History .....	i
Warranty .....	ii
Limitation Of Liability .....	ii
Patents .....	iii
Return Of Equipment .....	iii
Compliance Notices .....	iii
FCC Part 15 .....	iii
ACTA TIA/EIA IS-968A (Formerly FCC Part 68) .....	iv
IC CS03 (Industry Canada) .....	iv
EN55022 .....	iv
Safety .....	iv
Class 1 Laser Products .....	v
Laser Radiation and Connectors .....	v
Service Personnel Warning .....	vi
Conformité UL (E.-U. et Canada) .....	vi
Grounding .....	vi
Contacting Dymec .....	vi

## PREFACE

About This Manual .....	xi
Conventions .....	xi
Related Documents .....	xii
Web Access .....	xii
Comments .....	xii

## CHAPTER 1 INTRODUCTION

1.1 Overview .....	1-1
1.2 Specifications .....	1-3
1.2.1 Physical .....	1-3
1.2.2 Environmental .....	1-3
1.2.3 Optical Specifications .....	1-3
1.2.4 Compliance .....	1-4
1.2.5 Power Requirements .....	1-4
1.3 Controls and Indicators .....	1-5
1.3.1 Ports and External Connectors .....	1-5
1.3.2 <b>DYNASTAR 1500</b> Indicators .....	1-5

## CONTENTS

---

1.4	Pinouts.....	1-7
1.4.1	Ethernet Ports - RJ45 .....	1-7
1.4.2	Ethernet Ports - SFP.....	1-7
1.4.3	W1 DDS Port .....	1-8
1.4.4	T1/E1 Port.....	1-8
1.4.5	Alarm Port.....	1-9
1.4.6	Console Port.....	1-9
1.4.7	Null Modem Cable Wiring .....	1-10
1.4.8	Standard Serial Port .....	1-10
1.4.9	RS485 Port.....	1-11

## CHAPTER 2 PRE-INSTALLATION

2.1	Pre-Installation Requirements .....	2-1
2.1.1	Environmental.....	2-1
2.1.2	Rack Requirements .....	2-1
2.1.3	Power Requirements .....	2-2
2.1.4	Guidelines for Wiring and Grounding .....	2-2
2.1.4.1	Fiber.....	2-2
2.1.4.2	Grounding.....	2-2
2.1.4.3	Facility Power.....	2-2
2.1.5	Equipment Requirements.....	2-3
2.2	Safety and Handling.....	2-3
2.2.1	Laser Warning.....	2-3
2.2.2	Fiber Optic Handling .....	2-3
2.2.2.1	Fiber Cleaning Conventions .....	2-3
2.2.2.2	Fiber Handling.....	2-4
2.3	External Connections .....	2-4

## CHAPTER 3 INSTALLATION

3.1	Chapter Organization .....	3-1
3.2	Unpacking The <b>DYNASTAR 1500</b> .....	3-1
3.2.1	Install Optional Ethernet Fiber Optic SFPs .....	3-2
3.3	Installation.....	3-3
3.3.1	Rack Mounting.....	3-3
3.4	Connecting Facility Power.....	3-4
3.4.1	DC Power Connection and Applying Power .....	3-4
3.4.2	AC Power Connection .....	3-5
3.5	Connecting Facility Alarm/IRIG Inputs.....	3-6
3.6	Connecting Network Cables.....	3-7
3.6.1	Connecting Serial Cables.....	3-7
3.6.2	Connecting Ethernet Cables.....	3-7
3.6.3	Connecting Fiber Ethernet Cables .....	3-8
3.6.4	Connecting the WAN Cable .....	3-9
3.7	Verifying Installation .....	3-10

---

**CHAPTER 4    MAINTENANCE**

4.1    Removing the **DYNASTAR 1500**..... 4-1  
    4.1.1    Disconnecting Power and Ground Lines ..... 4-1  
    4.1.2    Disconnect Network Cables ..... 4-2  
4.2    Packing The **DYNASTAR 1500** For Shipment ..... 4-2  
4.3    Cleaning Fiber Optic Devices ..... 4-3  
    4.3.1    Cleaning Connectors..... 4-3  
    4.3.2    Cleaning Optical Ports ..... 4-4

**CONTENTS**

---

---

---

# PREFACE

---

---

## ABOUT THIS MANUAL

This document provides instructions to install the **DYNASTAR 1500 (DS1500-IFR, DS1500-XFR, and DS1500-ETS)** hardware. This document gives product descriptions, specifications, detailed information on ports and pinouts, all site preparation required to install the product, complete installation procedures, power up instructions, removing and maintaining the product. This document is arranged as follows:

**Chapter 1, “Introduction”** - Contains a brief product description, a list of applicable specifications, a discussion of the installation process, and a description of all controls and indicators and pinouts for connectors.

**Chapter 2, “Pre-Installation”** - Contains all site preparation that must be accomplished prior to installing the **DYNASTAR 1500**.

**Chapter 3, “Installation”** - Covers installing the **DYNASTAR 1500** in a rack, powering the unit up, and making all external connections.

**Chapter 4, “Maintenance”** - Covers replacing the **DYNASTAR 1500**.

## CONVENTIONS

There is one common convention used throughout the manual which is the use of callouts interspersed in the text of the document. These callouts, shown and described below, draw the user’s attention to a condition or situation that may require them to act or at least to be informed of. All callouts will appear immediately before the step which the callout information pertains. The callouts are listed below with descriptions of their uses and information content in the text fields.



**ELECTRICAL WARNING:** This format is used for Electrical Warnings. Callouts of this format are used to notify that a potential of electrocution exists and that a defined action could cause personal injury or death to occur.

---

---



**LASER WARNING:** This Warning is used to call attention to the fact that Laser output can cause serious damage to the eye.

---

---



**CAUTION:** Cautions are used to inform the user that a condition may exist or that inaction may cause damage to the equipment either being installed or in the system.



**NOTE:** Notes are used to provide the user with helpful information pertaining to an upcoming step or action. Not following the information contained in a Note will not adversely affect the operation of the unit but may save time or increase the understanding of the user.

## RELATED DOCUMENTS

The **DYNASTAR 1500** documentation is contained in two manuals for each product. This manual is one and the other is the appropriate *DYNASTAR 1500 Administrator's Guide*. The **Administrator's Guide** provides instructions to configure the **DYNASTAR 1500** in a network environment. The configuration instructions are a step-by-step explanation of the process of taking a new **DYNASTAR 1500** through all of the normal steps needed to get the unit into operation. Also included are explanations of the additional options available to the user for managing and monitoring the network.

## WEB ACCESS

All of the **DYNASTAR 1500** manuals are available in pdf format on the Dymec website, [www.dymec.com](http://www.dymec.com).

## COMMENTS

If you find an error or have a helpful tip on the layout or informational content of this or any other Dymec manual please feel free to contact us via email with any problems or helpful information. All enquiries will be responded to with a correction or whatever resolution is required. Please make all comments to [support@dymec.com](mailto:support@dymec.com) or phone a support engineer at (877) 463-9632.

---

---

# CHAPTER 1

## INTRODUCTION

---

---

This chapter contains a brief description of the physical attributes of the **DYNASTAR 1500** product and describes the LEDs, pinouts, and specifications covering the device.

### 1.1 OVERVIEW

There are three versions of the **DYNASTAR 1500**: the **DS1500-ETS**, the **DS1500-IFR**, and the **DS1500-XFR**. The **DS1500-ETS** provides connectivity to Ethernet and serial devices. The **DS1500-IFR** builds upon the **DS1500-ETS** and provides additional WAN access to a Frame Relay network. The **DS1500-XFR** builds upon the **DS1500-IFR** to include access to X.25 networks.

The **DYNASTAR 1500** comes in various configurations with a DDS or T1/E1 WAN port (**DS1500-IFR** and **DS1500-XFR**), five Ethernet ports (**DS1500-ETS**), eight Serial ports, and optional SFPs for all models. Typical configurations of the **DYNASTAR 1500s** are shown in **Figure 1-1** below. The **DS1500-ETS** comes with five copper (RJ45) ports as the standard configuration but as shown in the figure below can also be ordered with two SFPs.

#### DS1500-IFR/DS1500-XFR

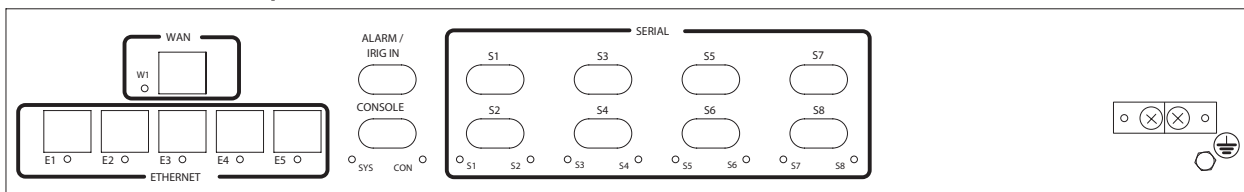

#### DS1500-ETS (Shown with optional SFPs)

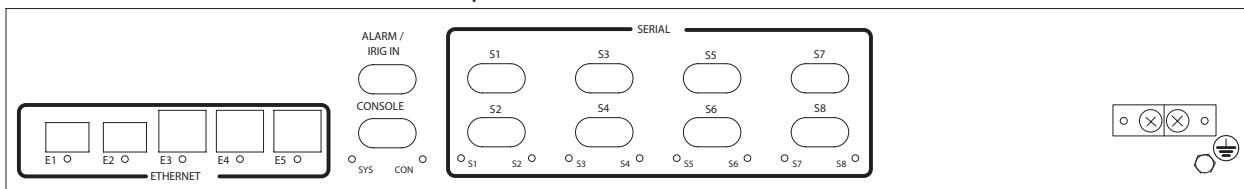

Figure 1-1. **DYNASTAR 1500** Configurations

The **DYNASTAR 1500s** serve basically two functions. All products provide connectivity to Ethernet and Serial devices, while the **DS1500-IFR** provides access to the Ethernet and Serial devices over a Frame Relay network and the **DS1500-XFR** provides access over an X.25 or Frame Relay network. The configurations without a WAN Port, **DS1500-ETS**, are used to provide on-site connectivity for Ethernet and Serial devices to local Ethernet networks. The figure below, **Figure 1-2**, shows the connectivity that the **DYNASTAR 1500** can provide. Note in the figure that the substation network is served by both products while the wide area connectivity is provided only by the **DS1500-IFR**.

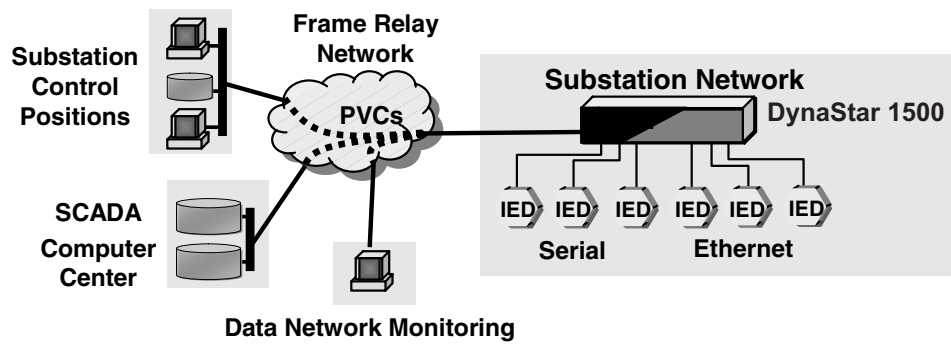

Figure 1-2. DYNASTAR 1500 Connectivity Example

## 1.2 SPECIFICATIONS

This section details the specifications covering the **DYNASTAR 1500**.

### 1.2.1 Physical

- Height: 2.6 inches (6.35 cm)
- Width: 17.5 inches (44.5 cm)
- Depth: 10 inches (25.4 cm)
- Weight: 9.5 lbs. (4.3 kg)

### 1.2.2 Environmental

- Operating Temperature: -40 to 75°C (-40 to 167°F)
- Storage Temperature: -40 to 85°C (-40 to 185°F)
- Operating Humidity: 5 to 95% non-condensing

### 1.2.3 Optical Specifications

All models support optional Small Form Pluggable (SFP) fiber optic ports. The specifications for these devices are included in the **Table 1-1**.

**Table 1-1. Fiber Optic Specifications**

DYNASTAR 1500 Optical Interface Specifications (Optional SFPs)							
Port Type	Conn. Type	Mode	Tx Power (dBm)		Rx Sensitivity (dBm)		Typical Max Dist.
			Min	Max	Min	Max	
100FX Pluggable SFP	LC	MM 1310nM	-19	-14	-28	-8	2 km
100FX Pluggable SFP	LC	SM 1310nM	-15	-8	-34	-10	15 km
100FX Pluggable SFP	LC	SM 1310nM	-5	-0	-34	-10	40 km
GigE Pluggable SFP	LC	SM 1310nM	-9	-3	-20	-3	10 km
GigE Pluggable SFP	LC	SM 1310nM	-7	-3	-24	-3	20 km

*“Typical maximum distance” is an estimated projection based on typical fiber installations; actual distance will depend on actual network attenuation. For all MM (multimode) optics, the recommended fiber cable type is 62.5 / 125 μm fiber. Selected others are supported, including 50 / 125 μm fiber for 100FX and 85/125 μm and 100/140 μm for 100 FX only. For 100FX SM (single mode) optics, the recommended fiber cable type is 9 μm SM fiber.*

## 1.2.4 Compliance

Safety			
UL60950	EN60950	CE Mark	CSA
Industrial			
IEEE 1613			
Emissions			
EN55022A, FCC Part 15A		VCCI, AS/NZ-3548	
Immunity			
EN55024-2003	EN61000-6-2	EN61000-4-2 (ESD)	EN61000-4-3 (RF)
EN61000-4-4 (EFT)	EN61000-4-5 (Surge)	EN61000-4-6 (CRF)	EN61000-4-11 (VDI)
Telecom			
ACTA TIA/ESI IS-968A (Formerly FCC Part 15)		EN55022:1998 Telco Port Emissions	

## 1.2.5 Power Requirements

The **DYNASTAR 1500** comes configured to be powered using AC or DC facility power. The **DYNASTAR 1500** is available with a high voltage AC or DC power supply or a low voltage DC power supply. The power requirements are listed in **Table 1-2**.

**Table 1-2. Power Requirements**

Power Supply Options				
Model	Voltage Nominal (V)	Voltage Input Range	Power (Watts)	Maximum Amperage (Amps)
High Voltage AC/DC	90/250 AC/DC	85 - 264 AC/DC	85	1
Low Voltage DC	24/48 DC	18 - 60 DC	81	4.5

## 1.3 CONTROLS AND INDICATORS

This section describes the controls and indicators as well as the pinouts for all of the **DYNASTAR 1500** ports.

### 1.3.1 Ports and External Connectors

Table 1-3. **DYNASTAR 1500** Ports

Port Name	Connector	Description
Ethernet E1 through E5	RJ45	10 or 100 Mbps Ethernet port for connection to copper Ethernet capable devices.
Ethernet E1 and E2 SFP	LC	Optional small form-factor pluggables (SFPs) 100 Mbps Ethernet port for fiber optic Ethernet capable devices or Networks.
WAN W1 DDS or T1/E1	RJ48	56/64 Kbps DDS CSU/DSU WAN connection, <b>DS1500-IFR/XFR</b> only.
	RJ48	T1/E1 CSU/DSU WAN connection, <b>DS1500-IFR/XFR</b> only.
Serial S1 through S8	DB9 (female)	Connection to serial async devices. Configurable to 300, 600,1200, 2400, 4800, 9600, and 19.2, 28.8, 33.6, 38.4, 57.6, 115.2, 230.4 Kbps.
Console	DB9 (female)	Port for local management session connections. Configured to operate at 9600 Baud, 7 bits, Even parity, one stop bit and is configured as a DTE.
Alarm/IRIG In	DB9 (female)	Carries Alarm signals concerning failure of the <b>DYNASTAR 1500</b> or some fault/alarm condition from a site monitor.
Power Connection	Screws	Nonpolarized power input.
Facility Ground Point	Lug bolt	Facility ground connection point.

### 1.3.2 **DYNASTAR 1500** Indicators

The **DYNASTAR 1500** has LED indicators associated with each port, which provide immediate information concerning the status of the connection. All of the **DYNASTAR 1500** LEDs are located on the rear of the unit. The LEDs are described in **Table 1-4**.

**Table 1-4. LEDs**

<b>LED Name/Location</b>	<b>Condition</b>	<b>Indication</b>
W1/Next to the WAN DDS or T1/E1 port	On	Indicates an active circuit
	Off	Indicates Frame circuit is down or not configured properly.
	Flashing	Data is passing through the port.
Link LED/Below Ethernet ports	On	Indicates connectivity to another active Ethernet device.
	Off	Indicates no connection to an active Ethernet device or network.
	Flashing	Data is passing through the port.
SYS - (System)/below Console port	Off	No power applied to unit
	Red	Reset state - system is not loaded
	Amber	System is being booted
	Green	Normal operation
CON (Console)	On	Indicates the console port is connected to an active local terminal.
	Off	No connection is made to the console port.
	Flashing	Data is passing through the port.
Serial port LEDs	On	Indicates that the serial port is connected to an active serial device.
	Off	Indicates that the serial port is down.
	Flashing	Data is passing through the port.

## 1.4 PINOUTS

The **DYNASTAR 1500** provides one or more of the following port types: WAN (**DS1500-IFR** and **DS1500-XFR** only), Ethernet, Serial, Alarm, and one Console port. The following paragraphs describe the types of connectors used and the Tables referenced with each connector type detail the pinouts. Included with the Console port table is a description of a null modem crossover cable. If you are connecting to the Console port and using terminal emulation to access the device, a null modem cable is required.

- Ethernet - RJ45 (See **Table 1-5 on page 1-7**)
- Ethernet - Optional 2 SFP Ports (See **Table 1-6 on page 1-7**)
- W1 WAN Port - RJ48 (See **Table 1-7 on page 1-8**)
- Alarm Port - DB9 connector (female) (See **Table 1-9 on page 1-9**)
- Console Port - DB9 connector (female) (See **Table 1-10 on page 1-9**)
- Null Modem Crossover Cable Wiring requirements (See **Table 1-11 on page 1-10**)
- Serial - DB9 connector (female) (See **Table 1-12 on page 1-10**)
- RS485 - DB9 connector (female) (See **Table 1-13 on page 1-12**)

### 1.4.1 Ethernet Ports - RJ45

**Table 1-5. Ethernet Ports - RJ45**

Pin	Signal
1	Tx +
2	Tx -
3	Rx +
4	Not Used
5	Not Used
6	Rx -
7	Not Used
8	Not Used

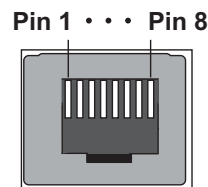

### 1.4.2 Ethernet Ports - SFP

**Table 1-6. Ethernet Ports - SFP**

Port	Signal
Tx	Transmit
Rx	Receive

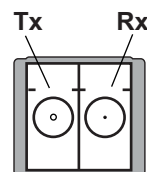

### 1.4.3 W1 DDS Port

**Table 1-7. W1 DDS Port - RJ48**

Pin	Signal
1	Tx Data - Ring
2	Tx Data - Tip
3	Not Used
4	Not Used
5	Not Used
6	Not Used
7	Rx Data - Tip
8	Rx Data - Ring

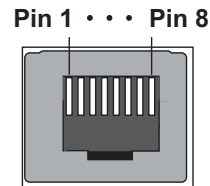

### 1.4.4 T1/E1 Port

**Table 1-8. W1 T1/E1 Port - RJ48**

Pin	Signal
1	Rx Data - Ring
2	Rx Data - Tip
3	Not Used
4	Tx Data - Ring
5	Tx Data - Tip
6	Not Used
7	Not Used
8	Not Used

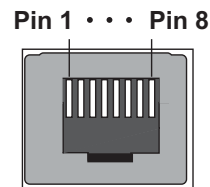

### 1.4.5 Alarm Port

Table 1-9. Alarm Port - DB9 female

Pin	Signal
1	NO1 - normally opened 1
2	NC1 - normally closed 1
3	COM2 - common 2
4	Reserved for future use
5	GND - signal ground
6	COM1- common 1
7	NC2 - normally closed 2
8	NO2 - normally opened 2
9	Reserved for future use

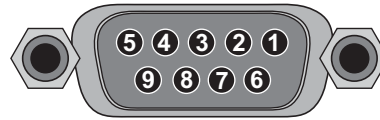

### 1.4.6 Console Port

Table 1-10. Console Port - DB9 female

Pin	Signal
1	DCD - Data Carrier Detect
2	RD - Receive Data
3	TD - Transmit Data
4	DTR - Data Terminal Ready
5	SGND - Signal Ground
6	DSR - Data Set Ready
7	RTS - Request To Send
8	CTS - Clear To Send
9	RI - Ring Indicator

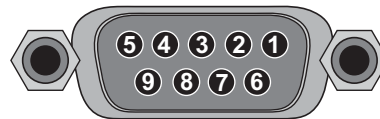

### 1.4.7 Null Modem Cable Wiring

**Table 1-11. Null Modem (Crossover) Cable Wiring**

Pin	Signal	Pin	Signal
1, 6	DCD, DSR	4	DTR
2	RD	3	TD
3	TD	2	RD
4	DTR	6, 1	DSR, DCD
5	SGND	5	SGND
7	RTS	8	CTS
8	CTS	7	RTS
9	RI	9'	RI

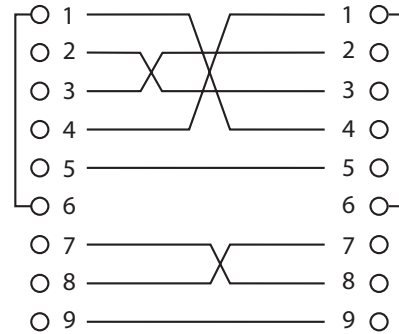

### 1.4.8 Standard Serial Port

**Table 1-12. Serial Port - DB9 female**

Pin	Signal
1	DCD - Data Carrier Detect
2	RD - Receive Data
3	TD - Transmit Data
4	DTR - Data Terminal Ready
5	SGND - Signal Ground
6	DSR - Data Set Ready
7	RTS - Request To Send
8	CTS - Clear To Send
9	RI - Ring Indicator

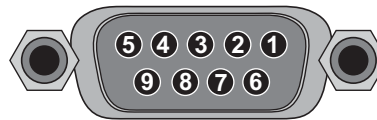

### 1.4.9 RS485 Port

RS485 is a serial communication method that is widely used in data acquisition and control applications and that allows multiple nodes to communicate with each other. The **DYNASTAR 1500** RS-485 interface module can operate in either 2-wire (half duplex) or 4-wire (full duplex) mode in point-to-point or multipoint configurations. In 2-wire mode, the transmitter is enabled only when the **DYNASTAR** has data to send and, once complete, the transmitter is tri-stated and the receiver is set to listening mode. In 2- or 4-wire mode, the **DYNASTAR** is generally the Master and all other attached devices are Slaves.

The administrator uses the port configuration menu to indicate whether 2-wire or 4-wire operation is being implemented. (See the appropriate *Administrator's Guide* for more information.)

**Figure 1-3** shows a 4-wire (full duplex) multipoint configuration; **Figure 1-4** shows a 2-wire (half duplex) multipoint configuration. **Table 1-13** gives the pinout information for the RS485 port.

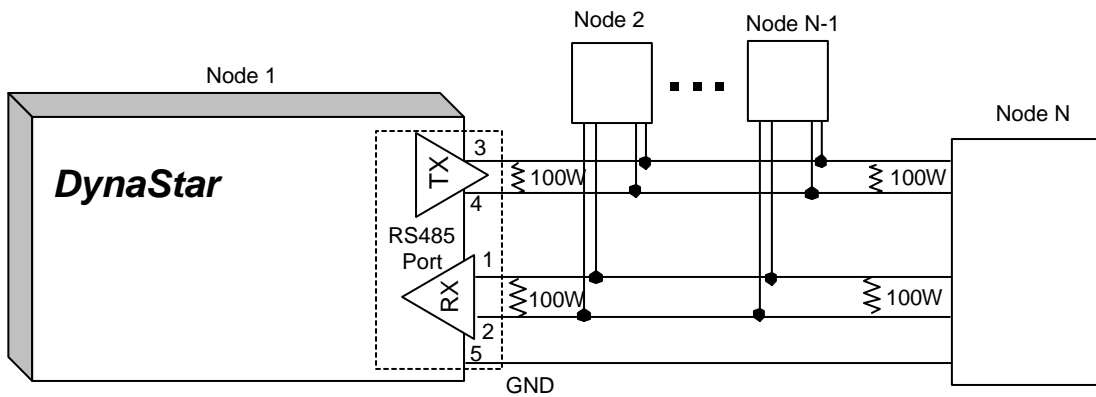

Figure 1-3. RS485 Full Duplex Multipoint Configuration

Note that, for full duplex operation, *five* wires are needed: RX- (pin 1), RX+ (pin 2), TX- (pin 3), TX+ (pin 4), and GND (pin 5). The ground connection must be made, as this is the reference for the transmit and receive pairs.

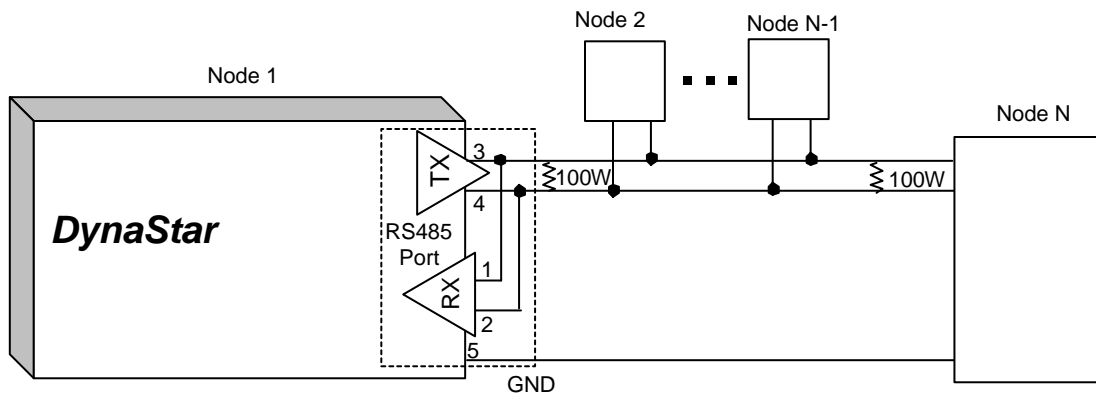

Figure 1-4. RS485 Half Duplex Multipoint Configuration

Note that, for half duplex operation, *three* wires are needed to the far end. Connect the RX pins to the TX pins in the mating connector (pin 1 to pin 3, and pin 2 to pin 4) as shown in **Figure 1-4**, and use pin 5 (GND). The ground connection must be made as this is the reference for the transmit and receive pairs.



NOTE: For all configurations, an external 100W termination resistor should be tied at the physical ends of the cable and connected across the TX and RX pair lines. To reduce noise, STP (shielded twisted pair) or FTP (foiled twisted pair) networking cables are recommended.

**Table 1-13. RS485 - DB9 female**

Pin	Signal
1	RX-
2	RX+
3	TX-
4	TX+
5	GND
6	Not Used
7	Not Used
8	Not Used
9	Not Used

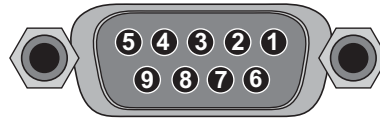

---

---

# CHAPTER 2

## PRE-INSTALLATION

---

---

*This chapter provides the installer with relevant information concerning the pre-installation of a **DYNASTAR 1500**. Installers should make themselves familiar with the requirements listed in this chapter prior to beginning the installation to ensure no unnecessary delays occur. This chapter details the power, environmental, space, and physical requirements for the hardware to operate properly.*

### 2.1 PRE-INSTALLATION REQUIREMENTS

The installation of the **DYNASTAR 1500** requires no special hand tools or other special equipment. The unit is designed to be installed in standard 19" racks. The installer will need a standard screw driver, torque wrench (rated for ten and 32 inch pounds) and a wrench to connect a ground wire from the device chassis ground to the rack. The instructions in this manual cover only the physical installation. The configuration, not described here, requires a terminal be connected to the device. The following sections detail the needs of the **DYNASTAR 1500** and what provisions must be present at the site for a safe and easy installation.

#### 2.1.1 Environmental

The operating characteristics of the **DYNASTAR 1500** are listed in the following table. Ensure that the installation site meets these criteria.

**Table 2-1. Environmental Conditions**

Condition	Requirement
Temperature - Storage	-40 to 85°C (-40 to 185°F)
Temperature - Operating	-40 to 75°C (-40 to 167°F)
Humidity - Operating	5 - 95% non condensing

#### 2.1.2 Rack Requirements

The **DYNASTAR 1500** is shipped with the standard 19" brackets installed. They can be rotated for non-standard installations. Before installing the **DYNASTAR 1500**, verify that the installation site meets the following requirements:

- The installation location will give access to the required network and power connections.
- The rack is not overloaded and that, after adding the **DYNASTAR 1500**, will remain stable and mechanical overloading will not occur.
- The **DYNASTAR 1500** requires two inches of free space from any other heat producing devices, to ensure that overheating does not occur. Example: The **DYNASTAR 1500** may be table or wall mounted. Direct contact with a non-heat generating surface will not cause an over heating condition. Stacking two **DYNASTAR 1500s** could cause either or both devices to fail due to heat build up between the devices.

### 2.1.3 Power Requirements

One external power source is required for each **DYNASTAR 1500**. The following power is required depending on the configuration of the **DYNASTAR 1500** and whether it is configured as AC or DC. Verify that the power provided to the **DYNASTAR 1500** meets these requirements.

**Table 2-2. Power Requirements**

<b>DYNASTAR 1500 Power Supply</b>	<b>Power</b>
High Voltage	0.6 Amps @ 120 VAC 0.3 Amps @ 240 VAC 0.6 Amps @ 125 VDC
Low Voltage DC	3.0 Amps @ 24 VDC 1.5 Amps @ 48 VDC

### 2.1.4 Guidelines for Wiring and Grounding

There are several types of connections being made to the **DYNASTAR 1500**. The types of cables which Dymec recommends are listed in the following sections. Unless specified these are recommendations and not requirements. Electrical connections listed here are requirements and should be followed to ensure safe operation of the unit.

#### 2.1.4.1 Fiber

The fiber cables connected to the **DYNASTAR 1500** must be non-dispersion shifted, single mode (SM) or multi-mode (MM) fiber cables defined by the Telcordia Technologies General Recommendation 20-CORE standard and terminated with LC connectors.

#### 2.1.4.2 Grounding

The primary ground stud located on the rear of the chassis must be used to connect to an approved ground using 14 AWG (minimum) wire, a maximum of five feet in length, terminated on the ground lug side with a #10 ring lug.

#### 2.1.4.3 Facility Power

Facility Power Cabling which attaches to the **DYNASTAR 1500** chassis must meet the following requirements:

- Facility Power Cabling shall be constructed using 14 AWG, stranded wire
- Facility Power Cable connector shall be affixed with a UL approved #6 Ring Lug, double crimped
- Facility Power Cable shall be affixed to the power connector with screw provided
- Facility Power Cable shall be routed and strain relieved to the chassis in such a manner as to follow good wiring practices.

## 2.1.5 Equipment Requirements

No special tools or test equipment are required for the installation. A common torque wrench (rated for ten to 32 in. pounds) is required for tightening the power and facility grounds.

## 2.2 SAFETY AND HANDLING

Prior to installing the **DYNASTAR 1500** please take a few moments to familiarize yourself with the following common safety issues that may be encountered while servicing this unit.

### 2.2.1 Laser Warning

There may be two Ethernet Fiber Optic ports which employ laser technology to transmit and receive communications. In most cases, even when the **DYNASTAR 1500** is powered down, the technician must assume there is still laser activity on the lines. Extreme caution must be exercised whenever handling the fiber lines. Do not look into the fiber tip or direct the tip towards anyone else. Care must also be exercised when disconnecting the fiber lines from the ports. Exposing the eye to the laser output could cause injury to the eye or blindness. Whenever tasks call for the technician to handle the fiber lines, and be exposed to laser output, a Laser Warning will appear in the text of this manual. The Laser Warning will appear as follows:



---

---

**LASER WARNING:** Laser output can cause serious damage to the eye. The lasers produced in the **DYNASTAR 1500** and from the connected device produce light that is invisible to the naked eye. It must be assumed at all times that the fiber optic cables and optical ports are radiating light energy. When connecting or handling the fiber cables or connectors, it is imperative that the technician avoid looking into the tip of the fiber or port.

---

---

### 2.2.2 Fiber Optic Handling

If the optional Fiber Optic Ethernet ports are used, installing and maintaining the **DYNASTAR 1500** requires the connection and disconnection of fiber optic cables. When disconnecting or connecting fiber optic cables to the **DYNASTAR 1500**, follow these cleaning and handling recommendations.

#### 2.2.2.1 Fiber Cleaning Conventions

Contamination from dust, dirt, oils from the hands and other sources can impede the transmission and reception of optical signals through the optical fibers. When handling the optical connectors and fiber cables, follow these precautions to minimize the contamination of the connectors and ports:

- Cover optical connectors and ports with dust caps when they are not in use.
- Do not touch fiber tips or the interior of optical ports when handling fiber cables and connectors.
- Clean fiber optic connectors as described in “Cleaning Connectors” on page 4-3 prior to making any optical connection.
- Clean optical ports as described in “Cleaning Optical Ports” on page 4-4 if contaminants or degraded performance are noted on the interface.

#### 2.2.2.2 Fiber Handling

Fiber optic cables and connectors are fragile and can be easily broken or fractured through mishandling. When handling fiber optic media, observe the following warnings:

- Do not strike the fiber cable with tools.
- Do not pinch, crimp, or compress the jacketing of the optical cable.
- Do not exceed the minimum bend radius of 3 inches (7.62 cm) when routing or coiling cables.
- Always exercise care when handling and routing fiber optic cables.



CAUTION: Avoid touching the fiber optic cable tips and interiors of the optical ports. If the connector or port is not being used, dust caps should be installed. Contamination could degrade the performance of the device. Dymec recommends that fiber optic connectors be cleaned after each use and optical ports be cleaned only if contamination or degradation to performance is detected.

## 2.3 EXTERNAL CONNECTIONS

To ensure that the **DYNASTAR 1500** can be made operational as quickly as possible, the WAN connection must be ready prior to the **DYNASTAR 1500** installation, and all interfacing cabling should already be laid between the **DYNASTAR 1500** installation location and the interfacing equipment. Once these connections are made, the **DYNASTAR 1500** can be configured using an attached terminal. It is assumed, therefore, that the following connections to other devices have been made and that no delays will be incurred due to the need to lay cables or contact service providers. The user should ensure that the following has been done:

- Ethernet cables ready to be connected to the **DYNASTAR 1500**, Dymec recommends Cat 5 cable be used
- Fiber optic cables available. Refer to **Table 1-1 on page 1-3** for cable and SFP types.
- Serial cables routed to the **DYNASTAR 1500** installation location
- Frame Relay or X.25 services have been obtained and the cabling from the service provider to the **DYNASTAR 1500** has been done
- The IP addresses for new devices in the network, like the **DYNASTAR 1500**, as well as the IPs for the desired endpoints, have been mapped and are ready to be entered during the configuration
- Frame Relay specific information is available and mapped to the desired connections (**DS1500-IFR** and **DS1500-XFR** only)
- X.25 specific information is available and mapped to the desired connections (**DS1500-XFR** only)
- Naming conventions and end point information is tabulated and ready

---

---

# CHAPTER 3

## INSTALLATION

---

---

*This chapter explains how to install the **DYNASTAR 1500**. It is assumed that the guidelines listed in the pre-installation section have been followed and the site is prepared for the installation. To install the **DYNASTAR 1500** follow the order as presented in the following section.*

### 3.1 CHAPTER ORGANIZATION

This chapter is divided into steps and sections. The sections are listed in **Table 3-1**, "Installation Procedures".

**Table 3-1. Installation Procedures**

Procedure	Page
Unpacking the <b>DYNASTAR 1500</b>	3-1
Installing Optional SFPs	3-2
Installing the <b>DYNASTAR 1500</b>	3-3
Connecting Facility Power Cables	3-4
Connecting Alarm/IRIG Cable	3-6
Connecting Network Cables	3-7
Verifying Installation	3-10

### 3.2 UNPACKING THE **DYNASTAR 1500**

Perform the following steps to unpack and inspect the **DYNASTAR 1500**.

The **DYNASTAR 1500** is shipped with the following items in the box: (if anything is missing from the shipping container contact Customer Support immediately.)

1. Open the shipping container and verify that the contents match those listed below:
  - **DYNASTAR 1500** with rack mounting brackets attached
  - Document CD-ROM
  - Console Cable - DB9 terminations, 6' long
  - Ethernet ribbon cable - RJ48 terminations, 6' long
2. Remove the unit from the styrofoam end caps and inspect the **DYNASTAR 1500** chassis for damage and insure that there are no dents, dings or other shipping related damage. Report any damage immediately to Dymec customer support and **DO NOT INSTALL** the unit.

### 3.2.1 Install Optional Ethernet Fiber Optic SFPs

The SFPs are optional equipment and are shipped in the accessory box with the unit. If more than one unit is shipped, all SFPs are packed in a single unit's accessory box. The outside of the shipping carton is labeled to indicate that the SFPs are packed inside. The SFP installation is a simple procedure of sliding the SFP into the Ethernet openings, E1 and E2. The following steps describe the installation.

1. Remove the SFP from the shipping container.



**CAUTION:** The SFPs are static sensitive devices. Use proper static safe handling precautions while handling the SFPs. Failure to handle these devices properly could cause them to fail immediately or prematurely. Use static safe wrist straps connected to the **DYNASTAR 1500**.

2. Remove the SFP from the antistatic bag.
3. Inspect the SFP for damage.  
Report any damage immediately to Dymec customer support and **DO NOT INSTALL** the SFP.
4. Slide the SFP into the desired Ethernet port opening until a click is heard.  
There are various SFPs available from different manufacturers. Most use a simple mechanism which locks the SFP into place once installed properly. An audible click should be heard when the SFP is "locked" into place.
5. Repeat steps 1 through 4 to install the other SFP.

## 3.3 INSTALLATION

This section describes rack mounting the **DYNASTAR 1500** in a rack. The unit comes prepared to be installed in a standard 19" rack either front, rear, or center rails. The mounting brackets may also be removed and rotated to support other configurations. Ensure the installation location allows room to connect power and network connections.

### 3.3.1 Rack Mounting

The following procedure details installing the **DYNASTAR 1500** in a standard 19" rack.



NOTE: Ensure that the brackets are installed for the type of installation desired. If the unit is to be installed in a position where the brackets are connected to a wall or to a shelf above the unit, remove the brackets and rotate them 90 degrees and reinstall using the same hardware.

If the unit is to be mounted on top of a sliding tray, remove the brackets and rotate them 90 degrees and reinstall the brackets using the same hardware.

Follow the steps below to install the **DYNASTAR 1500**.

1. Insert the **DYNASTAR 1500** into the rack opening until the mounting brackets contact the rails.
2. Align the holes in the mounting brackets with those in the rails.
3. Secure the **DYNASTAR 1500** to the rails using hardware appropriate for the rack and rail type.

## 3.4 CONNECTING FACILITY POWER

The **DYNASTAR 1500** comes in either high or low voltage models. The unit does not have a power on/off switch and is active when the power is connected. Always ensure that the ground connection is made prior to connecting facility power to the **DYNASTAR 1500**. The ground provides a protective circuit connection to ground in cases of transients and power surges. Connect the facility power to a DC or AC unit as described in the following sections.

### 3.4.1 DC Power Connection and Applying Power

The **DYNASTAR 1500** provides a hardened DC power supply for industrial applications and/or hostile environments. The power supply connector is located on the rear of the unit on the right hand side as shown in **Figure 3-1**. Connect the DC power to the unit as follows.



**NOTE:** The power supply connections are nonpolarized, meaning that positive and negative connections are automatically adjusted internally.

1. Ensure that the facility DC power is shut off to the wires being connected to the **DYNASTAR 1500**.
2. Lift the protective cover from the Power input and loosen the screws on the Power input and the Ground lug bolt beside the nonpolarized power inputs of the **DYNASTAR 1500**, as shown in **Figure 3-1**.

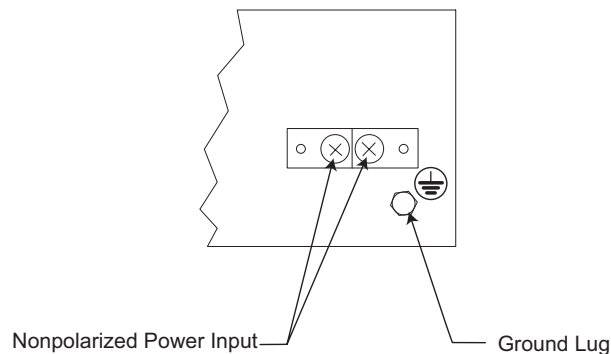

Figure 3-1. Power and Ground Connections

3. Connect the facility ground connection and torque the ground lug to 32 inch lbs. The ground wire should be 14 AWG and terminated with a #10 ring lug.
4. Connect the two facility DC wires to the nonpolarized power input points and tighten the screws to ten inch lbs. Push the protective cover over the screw heads and route the wires through the cutouts. The facility DC wires should be 14 AWG and be terminated with a #6 ring lug.



---

**ELECTRICAL WARNING:** Verify that a proper ground connection is made from the ground lug to facility ground prior to connecting power to the **DYNASTAR 1500**. Failure to have a proper ground path could cause serious injury or death to personnel in cases of power surges.

---

5. At the facility DC power source apply power to the **DYNASTAR 1500**.
6. The SYS LED, shown in **Figure 3-2 on page 3-6**, will illuminate green after roughly 20 seconds.

### 3.4.2 AC Power Connection

For AC powered units the connections are to the Power input terminals on the rear of the **DYNASTAR 1500** as shown in **Figure 3-1**. Connect AC power to the unit as follows:

1. Ensure that the facility AC power is shut off to the wires being connected to the **DYNASTAR 1500**.
2. Lift the protective cover from the Power input and loosen the screws and the Ground lug bolt beside the nonpolarized power inputs of the **DYNASTAR 1500**, as shown in **Figure 3-1**.
3. Connect the facility ground connection and tighten to 32 inch lbs.  
The ground wire should be 14 AWG and terminated with a #10 ring lug.
4. Connect the two facility AC wires to the nonpolarized power input points and tighten the screws to ten inch lbs. Push the protective cover over the screw heads and route the wires through the cutouts.  
The facility AC wires should be 14 AWG and be terminated with a #6 ring lug.



**ELECTRICAL WARNING: Verify that a proper ground connection is made from the ground lug to facility ground prior to connecting power to the DYNASTAR 1500. Failure to have a proper ground path could cause serious injury or death to personnel in cases of power surges.**

---

---

5. At the facility AC power source apply power to the **DYNASTAR 1500**.
6. The SYS LED, shown in **Figure 3-2 on page 3-6**, will illuminate green after roughly 20 seconds.

### 3.5 CONNECTING FACILITY ALARM/IRIG INPUTS

The Alarm/IRIG IN connector on the rear of the **DYNASTAR 1500** accepts a male DB9 connector. The inputs on these lines are made prior to the installation of the **DYNASTAR 1500**. The mating pairs are shown in **Table 1-9**. Refer to **Figure 3-2**.

1. Align the male DB9 connector with the DB9 Alarm/IRIG IN port, matching the arrangement of pins between the connector and port.
2. Press the connector into the Alarm/IRIG IN port to seat the connector.
3. If securing screws are available on the DB9 connector, tighten them to fasten the connector to the port.
4. Ensure that the cables are not hanging and their weight is supported. Strain relief on these cables will ensure that they do not demate any of the pins.

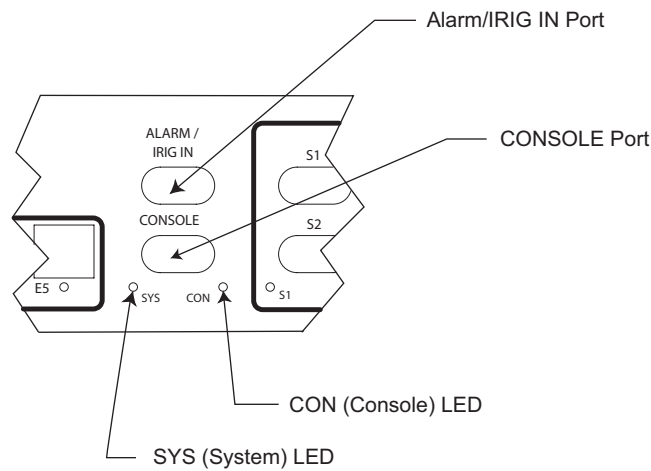

Figure 3-2. Alarm and Console Ports

## 3.6 CONNECTING NETWORK CABLES

There are three types of connections that can be made to the **DYNASTAR 1500**. They are WAN, Ethernet, and Serial. The following sections describe each type of connection separately. Note that not all connection types are available on every configuration of the unit and that there is one configuration which has fiber optic ethernet ports. Dymec recommends connecting the cables in the following order: Serial, Ethernet and then WAN.

### 3.6.1 Connecting Serial Cables

It is assumed that one end of the Serial device cable is already attached to the end unit. Ensure that the serial port numbering scheme is followed when installing the cables, refer to **Figure 3-3 on page 3-7**. The ports are configured in software later on and if a device is accidentally connected to the wrong port it will be difficult to detect. Connect cables to the Serial ports as described below:

1. Align the DB9 connector with the appropriate serial port and push gently until the connector is completely mated to the port.
2. Tighten the two extended capture screws hand tight.
3. Ensure that the cables are not hanging and their weight is supported. Strain relief on these cables will ensure that they do not demate some of the internal pins.
4. Return to step one above and connect the remainder of the cables.

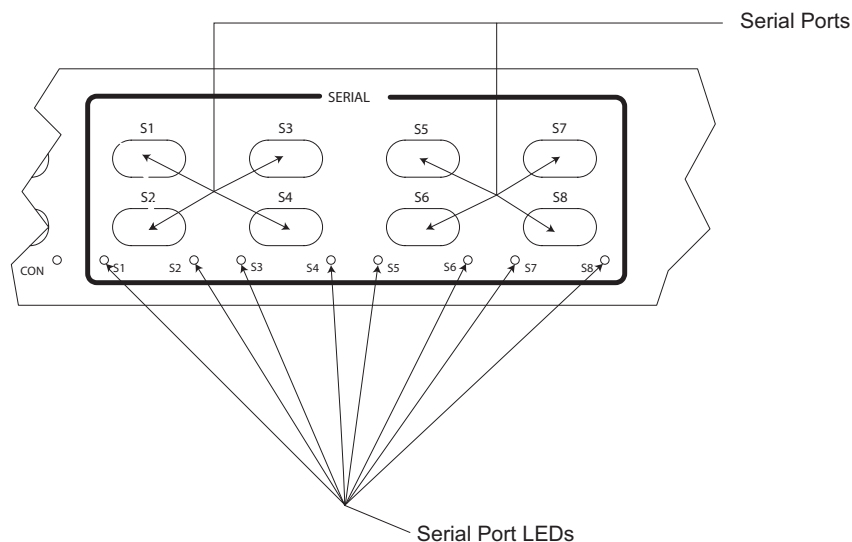

Figure 3-3. Serial Ports

### 3.6.2 Connecting Ethernet Cables

The Ethernet ports are standard RJ48 ports. Connect the standard Ethernet cables to the Ethernet ports as follows. (Refer to **Figure 3-4 on page 3-8**.)

1. Install the RJ48 connector into the port on the **DYNASTAR 1500**, with the clip facing down.
2. Push the RJ48 connector into the slot until an audible click is heard. Give the cable a little tug to ensure that the connector clip is firmly seated.

3. Ensure that the Link LED is illuminated for the port. See Figure 3-4 for location of the Link LED. If the Link LED is not on verify that the equipment on the other end of the cable is powered up.

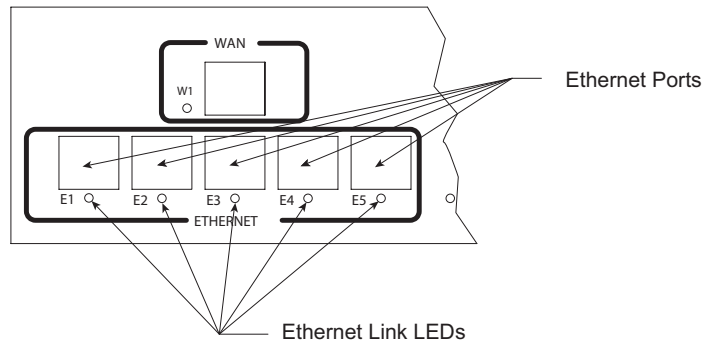

Figure 3-4. Ethernet Ports

### 3.6.3 Connecting Fiber Ethernet Cables

The **DYNASTAR 1500s** with optional SFPs contain fiber optic connections in Ethernet ports 1 and 2. The port accepts an LC type connector that slides on until the connector clicks into the port. Follow the safety precautions and steps to install the fiber optic cables to these ports and refer to **Figure 3-4** for Ethernet port locations.



**LASER WARNING:** Laser output can cause serious damage to the eye. The lasers used in the **DYNASTAR 1500** produce light that is invisible to the naked eye. It must be assumed at all times that the fiber optic cables and optical ports are radiating light energy. When connecting or handling the fiber cables or connectors, it is imperative that the technician avoid looking into the tip of the fiber or the port.



**CAUTION:** Avoid touching the fiber optic cable tips and interiors of the optical ports. If the connector or port is not being used, dust caps should be installed. Contamination could degrade the performance of the optical connection. Dymec recommends that fiber optic connectors be cleaned after each use and optical ports be cleaned only if contamination or degradation to performance is detected.

1. Remove the dust cap from the desired optical port and from the fiber cable end.
2. Visually inspect the cable end and the port for foreign contamination using caution not to look directly into the fiber tip.
3. Insert the fiber cable connector into the fiber port.
4. When the connector clicks into the port it is properly installed. Give the cable a soft tug to ensure it is securely installed.
5. Ensure that the cables are properly secured and do not hang freely. Excessive bending could cause damage to the fiber strand.
6. Repeat steps one through five to connect the other fiber cable

### 3.6.4 Connecting the WAN Cable

1. There is one WAN connection on the **DS1500-IFR** and one on the **DS1500-XFR**. The WAN port, see **Figure 3-5**, can be a DDS or a T1/E1 port. An RJ48 is used for both the DDS and the T1/E1 ports. This is a modular connector that connects the **DS1500** to the external telecommunications network. It is assumed that prior to connecting this interface that the line and telecom equipment are ready to accept data traffic from the **DS1500** and the interfacing cable is already attached to this gear.
2. Insert the RJ48 connector from the telecom gear into the WAN port on the **DS1500**. Ensure that the clip on the connector is facing down.
3. Once the connector clicks into the port, release the connector and give the cable a little tug to ensure it has mated properly with the port.
4. Once configured, verify that the W1 LED, see **Figure 3-5**, is illuminated.
5. Ensure that the cable has some strain relief and the weight of the cable will not cause the connector to misalign the connection with the port.

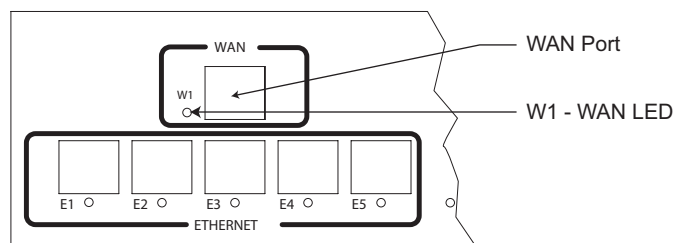

Figure 3-5. WAN Port

### **3.7 VERIFYING INSTALLATION**

At this point the **DYNASTAR 1500** should be completely installed in a rack or other suitable mounting location, power has been applied, all external network connections have been made, and the system is ready to be configured for data traffic. The instructions to configure the **DYNASTAR 1500** are found in the appropriate *Administrator's Guide* included on CD-ROM. Configuring the system requires a complete mapping of the network to be configured, alias names, Frame Relay information (**DS1500-IFR** and **DS1500-XFR** only), X.25 information (**DS1500-XFR** only), and a terminal to connect to the **DYNASTAR 1500**. Refer to the appropriate *Administrator's Guide* (**DS1500-IFR**, **DS1500-XFR**, or **DS1500-ETS**) for instructions to configure the equipment.

---

---

# CHAPTER 4

## MAINTENANCE

---

---

*There are no corrective repairs or preventive maintenance actions for the DYNASTAR 1500. The unit is designed to be replaced as a unit and there are no user repairable components in this device. There are also no requirements for servicing of this device. Therefore, the maintenance for the DYNASTAR 1500 is limited to replacing the unit and, in cases where optional SFP ports are installed, cleaning procedures for the fiber optic connectors and ports. The following sections detail disconnecting all connections to the chassis, removing the chassis, cleaning optical devices and packing the DYNASTAR 1500 for return to the manufacturer. If it is still possible to connect a terminal to the DYNASTAR 1500 and retrieve any configuration data from the device, do so prior to removing power.*

### 4.1 REMOVING THE DYNASTAR 1500

Removing the DYNASTAR 1500 entails disconnecting the power lines, disconnecting the network cabling, and removing the chassis from the rack or other installation location, and packing the DYNASTAR 1500 for shipment to the manufacturer. The following sections list, in order, the steps required to safely remove and prepare the unit for return to the manufacturer.

#### 4.1.1 Disconnecting Power and Ground Lines



**ELECTRICAL WARNING:** Prior to disconnecting either AC or DC power connections at the DYNASTAR 1500, ensure that the facility power has first been turned off. Failure to shut power off prior to removing the power connections could expose the technician to dangerous voltages causing injury or death.

---

---

1. Ensure that power to the DYNASTAR 1500 is turned off.
2. Lift the protective cover from the Power input and, using a screwdriver, loosen the two screws holding the power wires to the nonpolarized power connections and remove the wires from the connections.  
If the wires are not to be used immediately carefully wrap them to ensure that an accidental turning on of the power will not cause a short.
3. Remove the ground wire from the chassis by loosening the Ground Lug.

## 4.1.2 Disconnect Network Cables

The network connections to the **DYNASTAR 1500** may include Serial, Ethernet, and WAN (**DS1500-IFR** and **DS1500-XFR** only) cables. The order for removal is not important but it is important to note that there are active devices connected to each end of the cable. It is assumed that the power connections have been removed from the **DYNASTAR 1500**.

1. Remove all of the DB9 connectors from the Serial ports of the **DYNASTAR 1500**.  
Unscrew the two captive screws on each cable and pull the connector off the port.  
Label the connector with the port number if the cable is to be reconnected at some later time.
2. Remove the Ethernet RJ45 connectors from the Ethernet ports.  
Press on the clip on the underside of the modular connector and pull the connector straight out.  
Label the connector with the port number if the cable is to be reconnected at some later time.



**LASER WARNING:** The device that is connected to the other side of the fiber optic cable may still be sending information down this strand. Light that may be harmful to the human eye may still be radiating on this strand. Do not look in to the cable end after it is removed from the **DYNASTAR 1500** port as this light could cause permanent damage to the technician's eyes.

---

---

3. Following the safe handling procedures for fiber optic cables and connectors, remove any fiber optic cable connected to the Ethernet fiber ports.  
Immediately install dust caps on the cable end, just removed from the **DYNASTAR 1500**, and the fiber port.  
Label the connector with the port number if the cable is to be reconnected at some later time.
4. Remove the WAN RJ48 connector from the WAN port.  
Press on the clip on the underside of the modular connector and pull the connector straight out.  
Label the connector with the port number if the cable is to be reconnected at some later time.

## 4.2 PACKING THE DYNASTAR 1500 FOR SHIPMENT

If you have saved the shipping box that your **DYNASTAR 1500** was received in, then add the end styrofoam pieces around the chassis and place the unit in the box. Please contact customer support to receive a valid RMA number so that this item is either repaired and returned or credited to your account. Products without a proper RMA number will not be accepted for repair by Dymec, Inc.

If you have not saved the original shipping container then place the unit in a box so that normal shipping mistreatment will not cause any other damage to the unit. Dymec has no responsibility for the product during return shipping. Refer to the Warranty information, see "Warranty" on page ii, and the requirements to return equipment, see "Return Of Equipment" on page iii, for details.

## **4.3 CLEANING FIBER OPTIC DEVICES**

This section covers the cleaning requirements and procedures for the fiber optic cable connectors and the optical ports on the **DYNASTAR 1500**. It is recommended by the manufacturer that the connectors be cleaned after each use and the optical ports be cleaned only when contamination is suspected or there is a performance degradation that may be attributable to contamination. All fiber optic connectors and optical ports should be capped using dust caps when not in use.

The cleaning materials used should be rated for fiber optic devices. Specifically cloth, wipes and swabs should be lint-free, non-abrasive and free of additives. Cleaning fluids should be restricted to optical-grade isopropyl alcohol. Canned air should be used to blow out dust and particulate matter and to dry residual isopropyl alcohol after cleaning.

### **4.3.1 Cleaning Connectors**

These instructions are recommended each time a fiber optic connector is used. Clean the fiber optic connectors as follows:



**LASER WARNING:** Laser output can cause serious damage to the eye. The lasers used in the **DYNASTAR 1500** produce light that is invisible to the naked eye. It must be assumed at all times that the fiber optic cables and optical ports are radiating light energy. When connecting or handling the fiber cables or connectors, it is imperative that the technician avoid looking into the tip of the fiber or the optical port.

---

---

1. Blow out any dust or particulate matter from the connector end, using canned air.
2. Wipe out the connector end surfaces with a cloth or pad saturated in isopropyl alcohol.
3. Blow dry the connector surfaces, using canned air, by directing the air flow across the tip but not directly down onto the tip.
4. Using care not to touch the fiber tip, install a dust cap or connect to an optical port.

### 4.3.2 Cleaning Optical Ports

These instructions are recommended only when there is evidence of contamination or when reduced performance has been detected. Clean the optical ports as follows:



---

---

**LASER WARNING:** Laser output can cause serious damage to the eye. The lasers used in the **DYNASTAR 1500** produce light that is invisible to the naked eye. It must be assumed at all times that the fiber optic cables and optical ports are radiating light energy. When connecting or handling the fiber cables or connectors, it is imperative that the technician avoid looking into the tip of the fiber or the optical port.

---

---

1. If required, remove the fiber optic connector from the optical port and clean the connector as described in “Cleaning Connectors” on page 4-3.
2. Insert the extension tube, supplied with the canned air, into the canned air nozzle and blow out the optical port. Use care not to touch the bottom of the optical port.
3. Reconnect the fiber optic connector removed in step 1.

If degraded performance persists, perform the following additional steps:

4. Remove the fiber optic connector and place a dust cap on the end.
5. Using a small head swab gently wipe out the optical port. Repeat steps 2 and 3.