

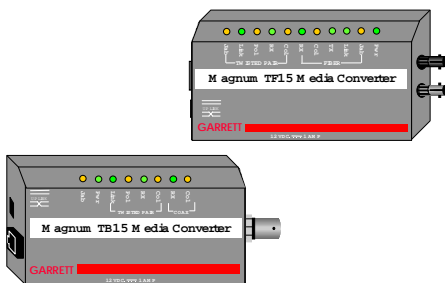

# GarrettCom<sup>®</sup>

*Industrial Networking at Its Best™*

## Magnum 10Mb/s Media Converters



Half- and full-duplex fiber models

## Installation and User Guide

**GARRETT**

# **Magnum™ 10Mb/s Media Converters**

## **Installation and User Guide**

Part#: 84-00001 (R07/98)

### **Trademarks**

UL is a registered trademark of Underwriters Laboratories

Ethernet is a trademark of Xerox Corporation

Velcro is a trademark of Velcro U.S.A.

**GARRETT**



**Important:** Magnum Media Converters contain no user serviceable parts. Attempted service by unauthorized personnel shall render any and all warranties null and void. If problems are experienced with a Magnum Media Converter, consult Section 5, Troubleshooting, of this User Guide.

©1998 Garrett Communications, Inc.

**GARRETT**



Please use the mailing address, email, phone and fax numbers listed below:

***GarrettCom, Inc.***

*47823 Westinghouse Drive*

*Fremont, CA 94539*

***Phone (510) 438-9071***

*Fax (510) 438-9072*

*email: support@garrettcom.com*

**GARRETT**



**FCC STATEMENT**

**FEDERAL COMMUNICATIONS COMMISSION**

**RADIO FREQUENCY INTERFERENCE STATEMENTS**

This equipment generates, uses, and can radiate radio frequency energy and if not installed and used properly, that is, in strict accordance with the communication. It has been tested and found to comply with the limits for a Class A computing device in accordance with the specifications in Subpart J of Part 15 of FCC rules, which are designed to provide reasonable protection against such interference when the equipment is operated in a commercial environment. Operation of this equipment in a residential area is likely to cause interference, in which case the user at his own expense will be required to take whatever measures may be necessary to correct the interference.



**TABLE OF CONTENTS****Page**

1.0 SPECIFICATIONS .....	1
1.1. Technical Specifications .....	1
2.0 INTRODUCTION .....	7
2.1 Inspecting the Package and Product .....	7
2.2 Product Description *** .....	9
2.3 Features and Benefits *** .....	16
2.4 Applications, TB15, BF15, and TP/fiber Link Pass-through *** .....	18
2.5 Full-duplex twisted-pair/fiber applications *** .....	21
3.0 INSTALLATION .....	22
3.1 Locating the Media Converter Unit .....	22
3.2 Calculating Overall Segment Distances .....	23
3.3 Connecting Ethernet Media .....	27
3.3.1 Connecting Twisted Pair (RJ-45, standard and Link Pass-through) .	27
3.3.2 Connecting ThinNet 10BASE2 (BNC) .....	29
3.3.3 Connecting Fiber (ST & SC, mm & sgl.mode, Full/half duplex)***	29

**GARRETT**

**TABLE OF CONTENTS (CONTINUED)****Page**

4.0 OPERATION .....	32
4.1 Power Requirements, Power Supply Types .....	32
4.2 Front Panel LEDs - Magnum TB15 .....	33
4.3 Front Panel LEDs - Magnum BF15 .....	34
4.4 Front Panel LEDs - Magnum TF15, TF15s, TF15SC, TF15-hdx *** .....	35
4.5 Up-Link (Cross-over) Switch.....	36
5.0 TROUBLESHOOTING.....	37
5.1 Before Calling for Assistance .....	38
5.2 When Calling for Assistance.....	40
5.3 Return Material Authorization (RMA) Procedure .....	41
5.4 Shipping and Packaging Information.....	43

Garrett Communications reserves the right to change specifications, performance characteristics and/or model offerings without notice.

\*\*\* Changes made in 1998. Fiber SC-type connector models, full- and half-duplex transparent operation fiber models, and Link Pass-through fiber models added.

**GARRETT**

**1.0 SPECIFICATIONS**

**1.1. Technical Specs - fiber full/half Models: TF15, TF15s, TF15SC, TF15LP and, standard “Collision-indicating” models: TB15, BF15, TF15-hdx**

**Performance:**

Data Rate: 10 Mbps (IEEE 802.3)

**Network Standards:**

Ethernet V1.0/2.0 IEEE 802.3: 10BASE2, 10BASE-T, FOIRL, 10BASE-FL

(Magnum Media Converters are physical layer standard Ethernet products, and operate independently of all software.)

**Number of Media Converters in series:**

*Experience shows that up to three units can be used in series between repeaters.*

*For 4 or more in series, noise build-up will typically preclude proper operation.*

**Maximum Standard Ethernet Segment Lengths:**

10BASE-T (unshielded twisted pair):	100 m (328 ft)
10BASE2 ThinNet (BNC):	185 m (607 ft)
FOIRL Fiber optic:	1.0 km (3,281 ft)
10BASE-FL Fiber optic :	2.0 km (6,562 ft)
10BASE-FL Single Mode Fiber optic:	10.0 km (32,810ft)

(for single-mode, full-duplex operation for distances over approx. 4Km.)

*Note: Magnum Media Converters **DO NOT** support full length Ethernet segments. See Section 3.2 of this manual for media lengths and segment distance calculations.*

**Operating Environment:**

Ambient Temperature: 32°F to 122°F (0°C to 50°C)

Storage Temperature: -20°C to 60°C

Ambient Relative Humidity: 10% to 95% (non-condensing)

**Power Supply (External):**

Power Input: 95 - 125 vac at 60 Hz for U.S. and Canadian models,  
200 - 250 vac at 50 Hz for international models which have  
IEC power cable connector.

Power Consumption: 6 watts max. for the Media Converter

**Connectors:**

RJ-45 Port: Modular 8-Pin female, with “cross-over” up-link switch

BNC Port: Standard BNC connector, RG-58 ThinNet

Fiber Port: Fiber optic (standard ST & SC types), 10BASE-FL

**Fiber, Full- and half-duplex:**

Fiber models capable of full- or half-duplex transparent operation have a tag on the bottom marked “FULL/HALF DUPLEX”, and do not indicate collisions.

**Packaging:**

Enclosure: High strength sheet metal.

Dimensions:

**TB15:** 2.5 in x 3.75 in x 0.75 in (6.35 cm x 9.53 cm x 1.9 cm)

**BF15:** 2.5 in x 3.75 in x 0.75 in (6.35 cm x 9.53 cm x 1.9 cm)

**TF15, TF15s, TF15SC, TF15LP, TF15-hdx:**

2.5 in x 3.9 in x 0.75 in (6.35 cm x 9.90 cm x 1.9 cm)

Power Supply: 2.0 in x 2.0 in x 1.5 in (5.1 cm x 5.1 cm x 3.8 cm)

Weight: **All Models:** 6.9 oz. (197g); power supply 10 oz (285g)

**Media Converter LED Indicators:**

<u>LED</u>	<u>TB15</u>	<u>BF15</u>	<u>TF15,TF15s, SC, LP,-hdx</u>	<u>Description</u>
PWR	unit	unit	unit	Indicates unit is receiving DC power.
Link	TP	Fiber	TP, Fiber	Steady ON when proper link is established at both ends of the segment.
RX	TP, BNC	BNC, Fiber	TP, Fiber	Indicates port is receiving packets.
TX	n.a.	BNC, Fiber	Fiber	Indicates port is transmitting packets
POL	TP	n.a.	TP	Indicates the unit has detected a TP receive wire-pair signal inversion (polarity).
COL*	TP, BNC	BNC, Fiber	TP, Fiber	Indicates unit is simultaneously transmitting and receiving data from the cables.
JAB*	unit	BNC	TP, Fiber	Indicates jabber (illegal packet length fault) condition. Segment is partitioned when lit.

**NOTE:**

\*COL and JAB LEDs (when present) are disabled for "FULL/HALF DUPLEX" units, which are transparent to the Collision and Jabber conditions and do not indicate them.

**GARRETT**

**Agency Approvals:**

115v 60 Hz Power Supply is UL Listed (UL 1310), CSA Certified

230v 50 Hz Power Supply is same, also TUV and GS approved

Emissions: Meets FCC Part 15 Class A, cUL

**Warranty:** Three years, return to factory

Made in USA

**GARRETT** 

## **2.0 INTRODUCTION**

This section describes the TF15, TF15s, TF15SC, TF15LP, TF15-hdx, TB15 and BF15 including appearance, features and typical applications.

### **2.1 Inspecting the Package and Product**

Examine the shipping container for obvious damage prior to installing this product; notify the carrier of any damage which you believe occurred during shipment or delivery. Inspect the contents of this package for any signs of damage and ensure that the items listed below are included.

This package should contain:

- 1 Magnum Media Converter Unit
- 1 External Power Supply, either 115 vac 60 Hz or 230 vac 50 Hz
- 1 Velcro® Tape section, approximately 3 inches in length
- 1 User Guide

Remove the Magnum Media Converter from the shipping container. Be sure to keep the shipping container should you need to ship the unit at a later date.

In the event there are items missing or damaged contact your supplier. If you need to return the unit use the original shipping container. Refer to Section 5, Troubleshooting, for specific return procedures.

**GARRETT** 

## **2.2 Product Description**

Magnum 10Mb Media Converters offer a compact, cost-effective way to adapt a pre-existing Ethernet cabling configuration as network requirements change. They offer a graceful way to convert and transmit data among twisted pair, thin coaxial and fiber network cabling environments. A variety of twisted-pair-to-fiber models provide for multi-mode or single-mode, full- or half-duplex, ST or SC connectors, and normal or Link Pass-through operation. Magnum Media Converters cost significantly less than full repeaters and can be used whenever media distance limitations will not be exceeded in the new environment. All units are compatible with Ethernet V 1.0 / 2.0 specifications and comply with IEEE 802.3 standards.

Magnum Media Converters are designed for quick and easy installation even in very tight spaces. Media cables are easily attached to the corresponding Media Converter. Because of their compact size, Magnum Media Converters can be Velcro®-mounted on an office wall or the side of a desk or cabinet. The external power supply plugs into a nearby AC wall socket or power strip. Each converter features a full set of LEDs that convey essential diagnostic and status information. See Section 4.1, LED Indicators, for specific LED function information.

Magnum Media Converters are designed to provide low-temperature operation over an extended period to make them some of the most reliable in the industry. Their high-strength fabricated metal packaging shields against Radio Frequency Interference (RFI) and Electromagnetic Interference (EMI).

Magnum Media Converters are specifically designed to convert data signaling to allow transmission between two different Ethernet cabling types, allowing migration to a new media type while preserving segments of the pre-existing wiring structure.

All of the Magnum Media Converters comply with the IEEE 802.3 10BASE-T specification for 10 Mb/sec traffic via shielded (STP) or unshielded twisted pair (UTP) segments. The Media Converters feature an up-link or cross-over switch to eliminate the need for a special cross-over cable when connecting to a hub or concentrator.

*Note: experience shows that the maximum number of 10Mb Media Converters that can be used in series is three. The cumulative noise from 4 or more units together causes packet alignment errors.*

The TB15 is equipped with one BNC and one RJ-45 port. The BNC connector complies with IEEE 802.3 10BASE2 specifications for ThinNet segments.

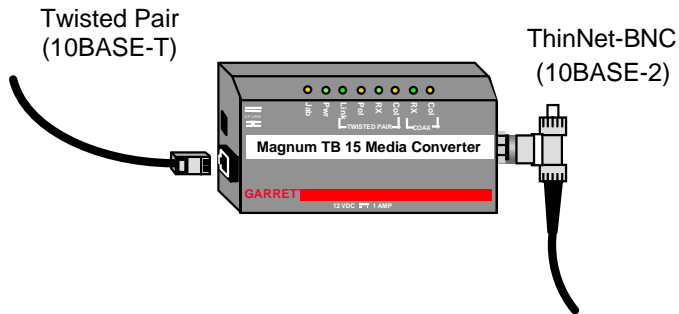

**The TB15 integrates 10BASE-T and 10BASE2 Ethernet networks.**

The Magnum BF15 is equipped with one BNC and one Fiber-ST connector for connection to IEEE FOIRL or 10BASE-FL compliant networks.

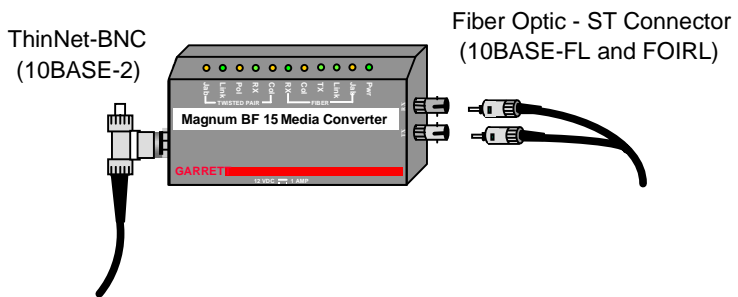

**The BF15 integrates ThinNet and Fiber Ethernet networks.**

**GARRETT**

The Magnum TF15 (multi-mode ST), TF15s (single-mode ST), TF15LP (Link Pass-through) and TF15-hdx (Half-duplex multi-mode ST) are equipped with one fiber-ST and one twisted pair RJ-45 connector for connection to IEEE FOIRL or 10BASE-FL compliant networks. All of these\* (except the TF15-hdx ) operate transparently at full- or half-duplex mode for devices at both ends.

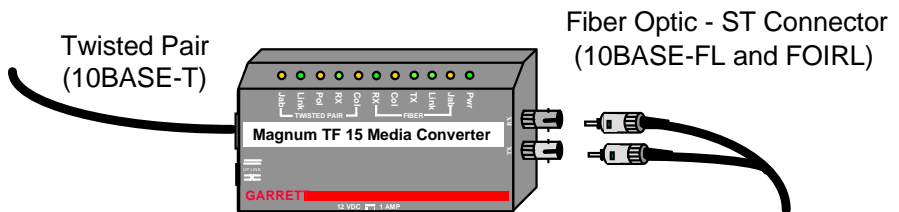

**The TF15 (ST type) integrates 10BASE-T and Fiber Ethernet networks.**

\*Non-Collision-indicating models are tagged "FULL/HALF DUPLEX" on the bottom.

**GARRETT**

The Magnum TF15SC\* has one fiber-SC (multi-mode) and one RJ-45 connector.

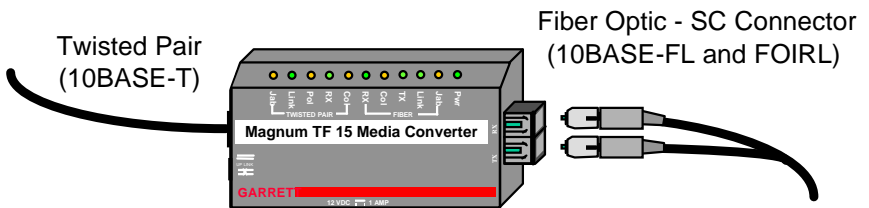

**The TF15SC (SC type) integrates 10BASE-T and Fiber Ethernet networks.**

\*Non-Collision-indicating models are tagged "FULL/HALF DUPLEX" on the bottom.

**GARRETT**

### 2.3 Features and Benefits

#### ■ Reduces Network Costs

Magnum Media Converters offer the ideal solution to quickly and inexpensively connect Twisted Pair with Fiber or ThinNet media within an expanding Ethernet network where full repeaters are not required.

#### ■ No added Repeater Hop Count

Media Converters do not add signal timing delays associated with full repeaters, and can be installed without increasing the repeater hop count of an existing network.

#### ■ Fiber / twisted-pair models for all fiber modes and media types

A variety of twisted-pair-to-fiber models provide for multi-mode or single-mode fiber, full- or half-duplex mode, ST or SC connectors, and normal or Link Pass-through operation.

- **Small, Compact, Lightweight Design**

Featuring a compact and lightweight metal case with an external power supply, Magnum Media Converters can be conveniently installed in minimal space on table-tops or wall-mounted.

- **Full Complement of LEDs.**

Each Media Converter model is equipped with a full complement of LEDs to provide network traffic status and basic diagnostic information without additional network diagnostic equipment.

- **Highly Reliable and Dependable**

Magnum Media Converters are based on a robust design and are packaged in a metal enclosures to ensure high reliability and durability.

## 2.4 Applications

The primary function of a Magnum Media Converter is to permit two different media types to coexist inexpensively within the same network by allowing data to be transmitted and received between different media types.

Magnum Media Converters are typically used where new 10BASE-T networking equipment is being installed and connecting to new / existing fiber or BNC Ethernet cabling is required. Alternatively, two twisted-pair-to-fiber models (typically TF15 for multi-mode and TF15s for single-mode) are convenient for inserting a fiber segment into a twisted pair environment in order to connect to a remote workstation or workgroup via fiber cabling, without increasing the repeater hop count.

The TF15LP, with the Link Pass-through feature, is often desired for managed networks, where the LINK indication passes-through from the fiber side to the TP side.

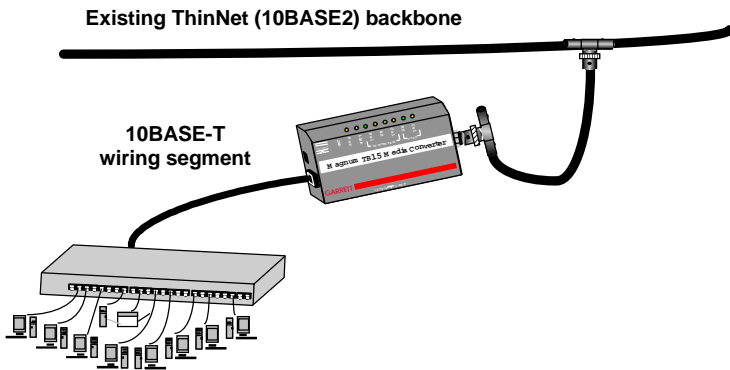

**Magnum TB15 provides connectivity for 10BASE-T devices through an existing BNC network tap.**

**GARRETT**

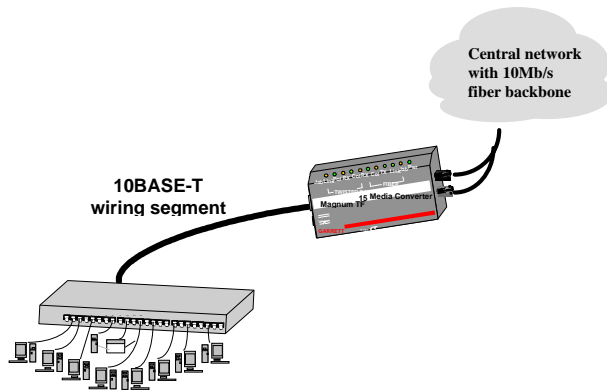

**Magnum TF15 provides connectivity between a fiber network and 10BASE-T network devices.**

**GARRETT**

Magnum Media Converters have an external power supply, enabling them to be used to convert signals among media that does not have a power source as part of the cabling system, such as twisted pair, BNC and Fiber. (AUI ports can supply power).

### **2.5 Full / half-duplex applications.**

Of the various 10Mb media types, only the twisted-pair to fiber combination is capable of full-duplex (i.e., simultaneously transmitting and receiving on the same cable segment) operation. Full-duplex is rarely required at 10Mb, but might occasionally be desired to connect a 10Mb RJ-45 switch port over a fiber link to a full-duplex RJ-45 NIC in a remote server, or to connect to another full-duplex 10Mb RJ-45 switch port.

The various TF15 units tagged FULL/HALF DUPLEX operate transparently to the simultaneous TX / RX condition, and do not indicate Collisions or Jabber even if they are present. They are suitable for all normal half- and full-duplex applications.

### 3.0 INSTALLATION

This section describes the installation of the Magnum Media Converters, including location, segment distance calculation and media connection.

#### 3.1 Locating the Media Converter Unit

The compact and lightweight design of the Magnum Media Converter allows it to be easily installed in almost any location. A Velcro strip is included for mounting the unit on a vertical surface such as a wall or cabinet, or for securing the unit on a table-top or shelf. Installation location is dependent upon the physical layout of the Ethernet network. Make sure the unit is installed in a location that will be easily accessible to an AC power outlet

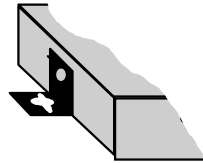

**Secure attachment of mounting clips for wall mounting**

or power strip, and where convection cooling is not inhibited.

For rack-mounting of media converters, the Magnum MC-TRAY is available.

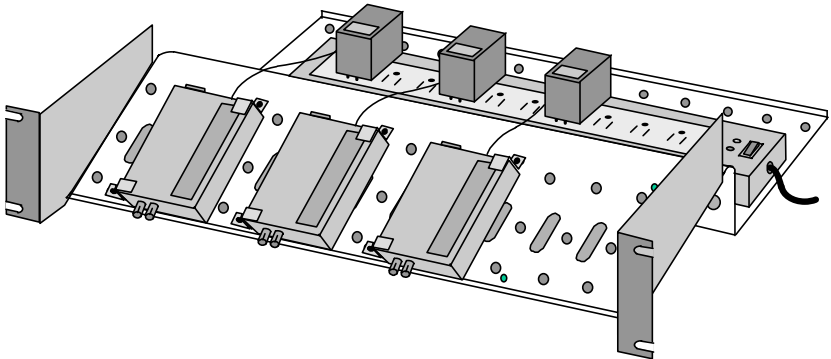

***Important Note:*** Special consideration must be given to maximum segment lengths on each side of the Magnum Media Converter. It is recommended that IEEE 802.3 specifications for overall maximum segment distances be adhered to in order to maintain optimum network performance. (See Technical Specs, Maximum Standard Ethernet Segment Distances, Section 1.1 of this manual.)

### **3.2 Calculating Overall Segment Distance**

When installing the Magnum Media Converter, it is important to consider the combined overall segment length of both of the attached media types. The overall segment length is calculated by adding together the segment lengths on both sides of the Magnum Media Converters. Segment length on each side of the Media Converter is

measured as a percentage of the maximum allowable standard media distance for the given media type. The percentages, when added together, must not exceed 100%.

**Media Distance \* Formula for Magnum Media Converters:**

$$X\% + Y\% \leq 100\%$$

Where **X** = The segment distance on one side of the Magnum Media Converter divided by the Standard Maximum Media Distance for that media type, x 100%

Where **Y** = The segment length on the other side of the Magnum Media Converter divided by the Standard Maximum Media Distance for that media cabling type, x 100%

**Notes:**

- 1) Media distance calculation is the same for both half and full duplex media converters.
- 2) Single-mode fiber distances more than approximately 4Km will exceed the collision

domain limits, and should be operated at either full-duplex or with light traffic.

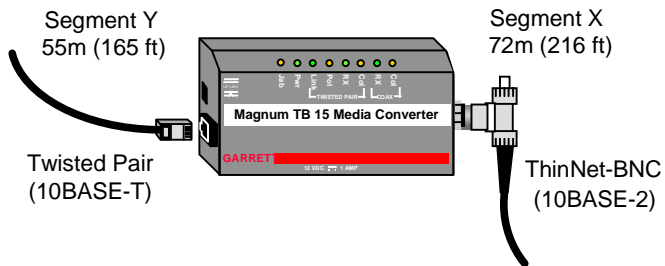
**A Distance Calculation Example:****Connectivity between ThinNet and TP Ethernet Media.**

In the figure shown above, the length of Segment X is 72m (216 ft). This is 39% of the maximum allowable distance for 10BASE2 media (185 m) [ $72/185 \times 100\% = 39\%$ ]. The length of Segment Y is 55m (165 ft). This is 55% of the maximum allowable

distance for UTP 10BASE-T media (100 m) [ $55/100 \times 100\% = 55\%$ ]. The total of the two percentages (39% + 55%) is 94%, which is allowable.

***Note 1:*** Where more than one media converter is used in one segment run, the percentages for all of the cabling lengths in the run must be added together and must not exceed 100%.

***Note 2:*** If the total segment distance calculation result is greater than 100%, consider using a Magnum Repeater so that each cable type can be 100% of its maximum allowed length.

***Note 3:*** The maximum number of 10Mb Media Converters that can be used in series is three. The cumulative noise from four or more units together causes packet alignment errors.

### **3.3 Connecting Ethernet Media**

Connecting Ethernet media to the Magnum Media Converter is very simple and straightforward. Using a properly terminated media segment, simply attach the cable end to the appropriate connector.

See Sections 4.2 and 4.3 for a description of the LEDs of the media converter models.

#### **3.3.1 Connecting Twisted Pair (RJ-45, standard and Link Pass-through models)**

The following procedure describes how to connect a 10BASE-T twisted pair segment to the RJ-45 port on the Magnum Media Converters. The procedure is the same for both unshielded and shielded twisted pair segments.

1. Using standard 10BASE-T media, insert either end of the cable with an RJ-45 plug into the RJ-45 connector of the Magnum Media Converter.
2. Connect the other end of the cable to the corresponding device.
3. Use the LINK LED (non-Link pass-through models) to ensure proper connectivity by noting that the LED will be illuminated when the units are powered and proper connections established. If the LINK LED is not illuminated, change the setting of the up-link switch (See Section 4.4 for up-link switch information.) If this does not help, ensure that the cable is connected properly at both ends and is not defective.
4. For the TF15LP model with the Link-Pass-through feature, The two LINK LEDs operate together, and either both LEDs are lit or neither is lit. Both of the attached cables must be operable for LINK to be indicated. Absence of LINK does not point to the problem cable segment, and the fault may be in either.

### 3.3.2 Connecting ThinNet 10BASE2

Connect the ThinNet coax cable to the BNC connector on the TB15 Media Converter in the same manner as is done for any standard BNC connection. Be sure that the BNC segment is properly terminated using a standard “T” connector and terminator.

### 3.3.3 Connecting Fiber Optic multi-mode, single mode

The following procedure applies to 10BASE-FL multi-mode and single mode applications using the TF15, TF15s, TF15SC, TF15LP and TF15-hdx Media Converters. All have ST-type fiber connectors, except the TF15SC which has SC-type connectors.

The TF15s single-mode differs from the other fiber media converters in terms of the maximum distance allowed. The others are used for a multi-mode fiber segment lengths of up to 2km. The TF15s is used for single-mode fiber segments of up to 10km in length. The following table is provided for general information:

**GARRETT** 



*Note: One strand of the duplex fiber optic cable is coded using color bands at regular intervals; you must use the color-coded strand on the associated ports at each end of the fiber optic segment.*

3. Connect the Transmit (TX) port (light colored post) on the Magnum Media Converter to the Receive (RX) port of the remote device. Begin with the color-coded strand of the cable for this first TX-to-RX connection.
4. Connect the Receive (RX) port (dark-colored post) on the product to the Transmit (TX) port of the remote device. Use the non-color coded fiber strand for this.
5. The LINK LED corresponding to the fiber port on the front of the product will illuminate (for standard non-Link-Pass-through models) when a proper connection has been established at both ends (and when power is ON in the units at each end). If LINK is not lit after cable connection, the normal cause is improper cable polarity. Swap the fiber cables on the product connector to remedy this situation.
6. For the Link Pass-through model, connection is the same except that the LINK indication will not be present unless LINK is made for the cables on both sides.

## **4.0 OPERATION**

This section describes the operation of the Magnum Media Converters including power supply requirements, up-link switch functionality, and a description of all LEDs.

### **4.1 Power Requirements, Power Supply Types**

Magnum Media Converters require 6 watts of power and are designed to be used with an external power supply. The external power supply unit supplied is one of two types; one version (U.S. and Canadian models) for AC input power of 115 vac 60 Hz, and one international version for 230 vac 50 Hz. The 115 vac version has a small transformer integral with a convenience power outlet plug. The 230 vac version has a small transformer integral with an IEC-type power plug for a user-supplied AC power cord with a convenience power outlet plug. Both types include a lightweight DC power cord to the applicable power jack on the Media Converter unit.

**4.2 Front Panel LEDs - - Magnum TB15**

<b><u>LED</u></b>	<b><u>Description</u></b>
<b>PWR</b>	Illuminates GREEN to indicate the unit is receiving DC power.
<b>LINK</b>	(TP) Illuminates GREEN, to indicate proper connectivity on the 10BASE-T network segment. LINK will turn off in the event connectivity is lost between the ends of the twisted pair segment or a loss of power occurs in the unit or remote device.
<b>RX</b>	(per port) Illuminates GREEN to indicate data is being received.
<b>POL</b>	(TP) Illuminates AMBER to indicate inverse polarity detected.
<b>JAB</b>	Illuminates AMBER to indicate jabber (illegal packet length).
<b>COL</b>	(per port) Illuminates AMBER to indicate a collision on the segment.

**4.3 Front Panel LEDs - - Magnum BF15**

<b><u>LED</u></b>	<b><u>Description</u></b>
<b>PWR</b>	Illuminates GREEN to indicate the unit is receiving DC power.
<b>LINK</b>	(TP) Illuminates GREEN, to indicate proper connectivity on the 10BASE-T network segment. LINK will turn off in the event connectivity is lost between the ends of the twisted pair segment or a loss of power occurs in the unit or remote device.
<b>RX</b>	(per port) Illuminates GREEN to indicate data is being received.
<b>TX</b>	Illuminates GREEN to indicate attached host is transmitting data over the cable.
<b>JAB</b>	Illuminates AMBER to indicate jabber (illegal packet length).
<b>COL</b>	(per port) Illuminates AMBER to indicate a collision on the segment.

**4.4 Front Panel LEDs - Magnum TF15, TF15s, TF15SC, TP15LP, TF15-hdx**

<b><u>LED</u></b>	<b><u>Description</u></b>
<b>PWR</b>	Illuminates GREEN to indicate the unit is receiving DC power.
<b>LINK</b>	(per port) Illuminates to indicate proper connectivity on each cable segment (non-Link Pass-through models). LINK will turn off in the event connectivity is lost between the ends of each cable segment or a loss of power occurs in the unit or in the attached device. For Link Pass-through models, see Section 3.3.3 #6.
<b>RX</b>	(per port) Illuminates GREEN to indicate data is being received.
<b>TX</b>	(Fiber) Illuminates GREEN to indicate data is being transmitted
<b>POL</b>	(TP) Illuminates AMBER to indicate inverse polarity detected.
<b>JAB*</b>	(per port) When present, illuminates to indicate half-duplex Jabber (illegal packet length) condition. (Inoperable or not present on models with the FULL/HALF DUPLEX tag on the unit's bottom).
<b>COL*</b>	(per port) When present, illuminates to indicate a half-duplex Collision on the segment. (Inoperable or not present on models with the FULL/HALF DUPLEX tag on the bottom of the unit).

\* Not applicable to FULL/HALF DUPLEX models, including Link-Pass-through.

#### 4.5 Up-Link (Cross-over) Switch

Magnum Media Converters are equipped with an up-link slide switch on the RJ-45 port to accommodate repeater-to-converter and switch-to-converter connections without a special cross-over cable.

##### 4.5.1 Up-Link (Cross-over) Switch

When set to the UP position (=), the Magnum Media Converter is wired for normal twisted-pair connection to a user node device. When set to the DOWN position (X), the Media Converter is wired with cross-over functionality for direct up-link to a network hub or concentrator. Switch ports may be of either polarity, and this feature is most convenient with switches..

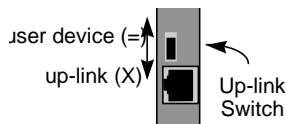

**End view, TP port**

## **5.0 TROUBLESHOOTING**

All Magnum Ethernet products are designed to provide reliability and consistently high performance in all network environments. The installation of Magnum Media Converters is a simple procedure (see Section 3.0, INSTALLATION); operation is very simple and is described in Section 4.0, OPERATION.

Should problems develop during installation or operation, this section should help to locate, identify and correct such problems. Please follow the suggestions listed below prior to contacting your supplier. However, if you are unsure of any procedure described in this section, or if the Magnum Media Converter is not operating as expected, do not attempt to repair or alter the unit. Contact your supplier (or if unknown, contact Garrett Communications) for assistance.

**5.1 Before Calling for Assistance**

1. If difficulty is encountered when installing or operating the Magnum Media Converter, refer back to Section 3.0, Installation and Section 4.0, Operation. Check to make sure that the various other components of the network are operable.
2. Check the cables and connectors to ensure that they have been properly connected, and the cables/wires have not been crimped or in some way impaired during installation. (About 90% of network downtime can be attributed to wiring and connector problems.)
3. Make sure that the external DC power supply is properly attached to the unit, that it is of the proper type, and that it is plugged into a functioning electrical outlet. Use the PWR LEDs to verify the unit is receiving proper power.

4. If the problem is isolated to a network device other than the Magnum Media Converter, it is recommended that the problem device be replaced with a known good device. Verify whether or not the problem is corrected. If not, go to Step 5 below. If the problem is corrected, the Magnum Media Converter and its associated cables are functioning properly.

5. If the problem continues after completing Step 4 above, contact your supplier of the Magnum Media Converter (or if unknown, contact Garrett Communications) by fax, phone or email for assistance.

## 5.2 When Calling for Assistance

Please be prepared to provide the following information.

1. A complete description of the problem, including the following points:
  - a. The nature and duration of the problem;
  - b. Situations when the problem occurs;
  - c. The components involved in the problem;
  - d. Any particular application that, when used, appears to create the problem;
2. An accurate list of Garrett Communications product model(s) involved, with serial number(s). Include the date(s) that you purchased the products from your supplier.
3. It is useful to include other network equipment models and related hardware, including personal computers, workstations, terminals and printers; plus, the various network media types being used.
4. A record of changes that have been made to your network configuration prior to the occurrence of the problem. Any changes to system administration procedures should all be noted in this record.

### **5.3 Return Material Authorization (RMA) Procedure**

All returns for repair must be accompanied by a Return Material Authorization (RMA) number. To obtain an RMA number, contact Garrett Communications Customer Support at (510) 438-9071 (office hours: 8AM - 5PM Pacific Standard Time) or send email to [support@garrettcom.com](mailto:support@garrettcom.com). Please have the following information available when calling:

- Name and phone number of your contact person.
- Name of your company / institution
- Your shipping address
- Product name
- Serial Number (or Invoice Number)
- Packing List Number (or Sales Order Number)
- Date of installation
- Failure symptoms, including a full description of the problem.

Garrett Communications will carefully test and evaluate all returned products, will repair products that are under warranty at no charge, and will return the warranty-repaired units to the sender with shipping charges prepaid (see Warranty Information, Appendix A, for complete details). However, if the problem or condition causing the return cannot be duplicated by Garrett Communications, the unit will be returned as:

**No Problem Found.**

Garrett Communications, Inc. reserves the right to charge for the testing of non-defective units under warranty. Testing and repair of product that is not under warranty will result in a customer (user) charge.

**5.4 Shipping and Packaging Information**

Should you need to ship the unit back to Garrett Communications, please follow these instructions:

1. Package the unit carefully. It is recommended that you use the original container if available. Units should be wrapped in a "bubble-wrap" plastic sheet or bag for shipping protection. ( You may retain all connectors and this Installation Guide.)

**CAUTION**

**Do not pack the unit in Styrofoam "popcorn" type packing material. This material may cause electro-static shock damage to the unit.**

2. Clearly mark the Return Material Authorization (RMA) number on the outside of the shipping container.
3. Garrett Communications is not responsible for your return shipping charges.
4. Ship the package to:

**GarrettCom, Inc.**  
**47823 Westinghouse Drive**  
**Fremont, CA 94539**  
**Attn.: Customer Service**