

# SubStation Hardened Ethernet Copper to Fiber Links



## For Reliable Substation Communications

### Technical Description

DYMEC models 3340, 3350, 3344 and 3354 are hardened fiber optic links that convert 10Base-T Ethernet from twisted pair copper to 10Base-FL or Single-mode fiber optics.

DYMEC models 3440, 3450, 3442, 3452, 3444 and 3454 are hardened fiber optic links that convert 100Base-T Ethernet from twisted pair copper to 100Base-FX, 100Base-SX or Single-mode fiber optics.

These links are stand-alone mounted and require no programming or set up. Simply mount the Link in an appropriate location and connect power. DYMEC Links are powered from various sources. The standard models accept 90 to 250 Volts ac or dc. Optionally, these Links can also be ordered for 12 or 24 to 48 Volts dc. The power supplies are surge withstand protected to both IEC 63000 and IEEE C37.90 standards.

- IEEE 802.3 compatible
- 2 RJ45 connectors eliminates the worry over crossover or straight cables
- Automatic Polarity detection and correction
- Auto adapts to Half or Full Duplex mode

## Features and Benefits

- Link Pulse Pass Through or Link Pulse Shut Down Modes are user selectable
- Conformal coated PC Boards
- Powered from Station Battery Bus to C37.90 or 12 Vdc
- Operates reliably at temperatures of -40°C to 85°C with no fans.
- Extended distances of 2 km over Multi-mode fiber and 12 km over Single-mode fiber. (Restrictions apply when connecting via hubs into networks)
- Multiple Mounting choices with built-in mounting brackets and optional mounting shelf
- Packaged in rugged, industrial-quality Galva Neal and powder coated shells
- Each data channel has its own diagnostic LEDs for easier debug of installation
- 5- year warranty



**Model 3340**

**Model 3350**

**Model 3440**

**Model 3450**

TECHNICAL BULLETIN TB3340

# Ethernet Link Specifications

	3340/3350 10 Base Ethernet		3440/3450 100 Base Ethernet	
Optical Parameters @ Maximum Temp	Multimode	Single-Mode	Multimode	Single-Mode
Optical Budget Minimum	13.5 dB	8.6 dB	9.0 dB	8.6 dB
Output power Minimum	-16 dBm peak	-19.9 dBm peak	-19 dBm peak	-19.9 dBm peak
Receiver Sensitivity Minimum	-29.5 dBm peak	-28.5 dBm peak	-28 dBm peak	-28.5 dBm peak
	(62.5µ/125 Multimode)	(9µ/125 Single-mode)	(62.5µ/125 Multimode)	(9µ/125 Single-mode)
Wavelength	850nm	1310nm	1300nm	1310nm
Connector Type	ST			
Compatible Fiber Type	Multimode (50-200µm)	Single-Mode (9-13µm)	Multimode (50-200µm)	Single-Mode (9-13µm)
Configuration (Switches)	Link Pass-Through/ Link Fail			
Data Rate	10Mbps		100Mbps	
Data Transmission	Half or Full Duplex			
Transmission Distance	up to 2000 meters	up to 10K meters	up to 2000 meters	up to 10K meters
	(62.5µ/125 Cable @3dB/km)	(9µ/125 Cable @0.5dB/km)	(62.5µ/125 Cable @3dB/km)	(9µ/125 Cable @0.5dB/km)
Bit Error Rate	10-E9 Max.			
Point to Point Latency	100 nsec			
<b>Electrical Parameters</b>				
<b>Inputs</b>				
I/O Data Format	802.3 Ethernet		802.3 Ethernet	
Data Connector	2 RJ45		2 RJ45	
<b>Ambient Temperature</b>				
Operating Temperatures	-40 to +85 C	-40 to +70 C	-40 to +85 C	-40 to +70 C
Storage Temperature	-40 to +85 C			
<b>Power Required</b>				
3X50	5.4 Watts			
	60 mA @ 90-250 V			
	300 mA @ 18-60 V			
3X40	4.0 Watts			
	333 mA @ 12Vdc			
Power Dissipation BTU/H				
3X50	18.4 BTU			
3X40	13.7 BTU			
<b>Physical Parameters</b>				
Weight				
3X50	17 Ozs.			
3X40	9 Ozs.			
Dimensions Inches				
3X50	4.1W X 5.1L X 1.3H			
3X40	2.0W X 5.1L X 1.3H			
Indicators	Power			
	Fiber Link			
	Electrical Link			
	Fiber Data			
	Electrical Data			

**Specifications Subject to Change Without Notice**

## Link Pass Through Mode

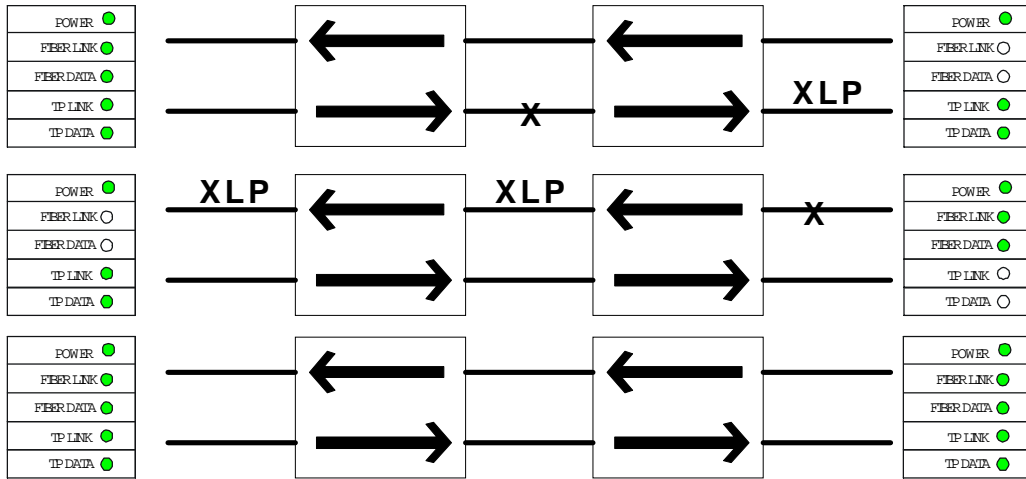

The Diagram above shows the operation of the 3340-3350 10Base Ethernet Links when the Link Pulse option is set to Pass-through mode (Switch marked ONE/FULL set to ONE).

The Bottom diagram shows the 3340 links diagnostic LED's in normal operation. The Data LED's both Fiber and TP will flash when data is actually passing and be off when no data is being transmitted. The Link LED's both Fiber and TP should be on Solid as long as the Power LED is also on.

The Middle diagram shows the 3340 links diagnostic LED's when the TP input cable of one of the links is open or damaged. Both of the 3340's show loss of received Link Pulses (one shows Fiber and one shows TP). The 3340 link on the opposite end of the fiber will not be transmitting TP link pulses to the connected IED).

The Top diagram shows the 3340 links diagnostic LED's when one of the fiber cables from one of the 3340 links is open or damaged. Only One of the 3340 links show loss of received Link Pulses (The receive fiber of the 3340 link on the opposite end of the break. That 3340 links TP port will not be transmitting link pulses to the connected IED).

## Link Fail Mode

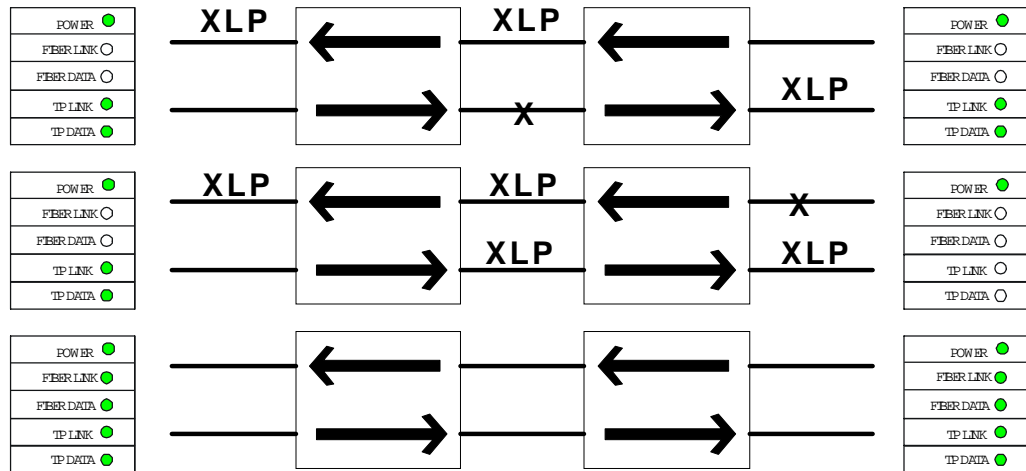

The Diagram above shows the operation of the 3340-3350 10Base Ethernet Links when the Link Pulse option is set to Fail mode (Switch marked ONE/FULL set to FULL).

The Bottom diagram shows the 3340 links diagnostic LED's in normal operation. The Data LED's both Fiber and TP will flash when data is actually passing and be off when no data is being transmitted. The Link LED's both Fiber and TP should be on Solid as long as the Power LED is also on.

The Middle diagram shows the 3340 links diagnostic LED's when the TP input cable of one of the 3304 links is open or damaged. Both of the 3340's show loss of received Link Pulses (Both of the 3340 links TP ports will not be transmitting link pulses to the connected IEDs).

The Top diagram shows the 3340 links diagnostic LED's when one of the fiber cables from one of the 3340 links is open or damaged. Both of the 3340 links show loss of received Link Pulses (Both of the 3340 links TP ports will not be transmitting link pulses to the connected IEDs).

# Ordering Information

Model	Input	Fiber Type	Input Power Rating	802.3 Standard
3340HRT	10 Base-T	Multimode	9 - 15 Vdc	10Base-FL
3350HRT-H	10 Base-T	Multimode	90-250 Vdc/ 90-250 Vac	10Base-FL
3350HRT-L	10 Base-T	Multimode	24 to 48 Vdc	10Base-FL
3344HRT	10 Base-T	Single-Mode	9 - 15 Vdc	Single-Mode
3354HRT-H	10 Base-T	Single-Mode	90-250 Vdc/ 90-250 Vac	Single-Mode
3354HRT-L	10 Base-T	Single-Mode	24 to 48 Vdc	Single-Mode
3440HRT	100 Base-TX	Multimode	9 - 15 Vdc	100Base-SX
3450HRT-H	100 Base-TX	Multimode	90-250 Vdc/ 90-250 Vac	100Base-SX
3450HRT-L	100 Base-TX	Multimode	24 to 48 Vdc	100Base-SX
3442HRT	100 Base-TX	Multimode	9 - 15 Vdc	100Base-FX
3452HRT-H	100 Base-TX	Multimode	90-250 Vdc/ 90-250 Vac	100Base-FX
3452HRT-L	100 Base-TX	Multimode	24 to 48 Vdc	100Base-FX
3444HRT	100 Base-TX	Single-Mode	9 - 15 Vdc	Single-Mode
3454HRT-H	100 Base-TX	Single-Mode	90-250 Vdc/ 90-250 Vac	Single-Mode
3454HRT-L	100 Base-TX	Single-Mode	24 to 48 Vdc	Single-Mode

**Accessories**  
 ACC-LCS                      Optional Mounting Bracket

## Outline Drawings

Model 3340  
Model 3440

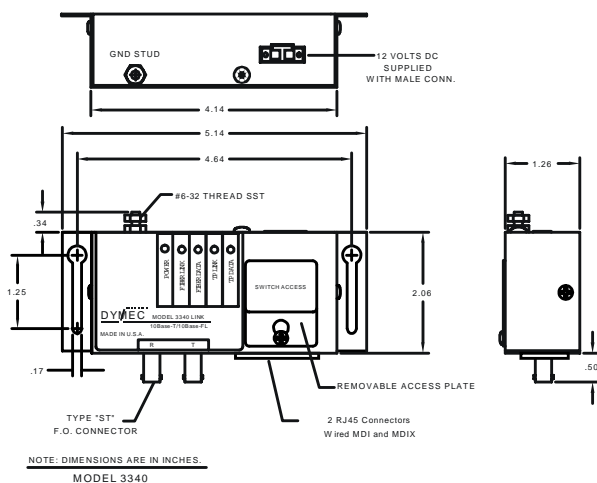

Model 3350  
Model 3450

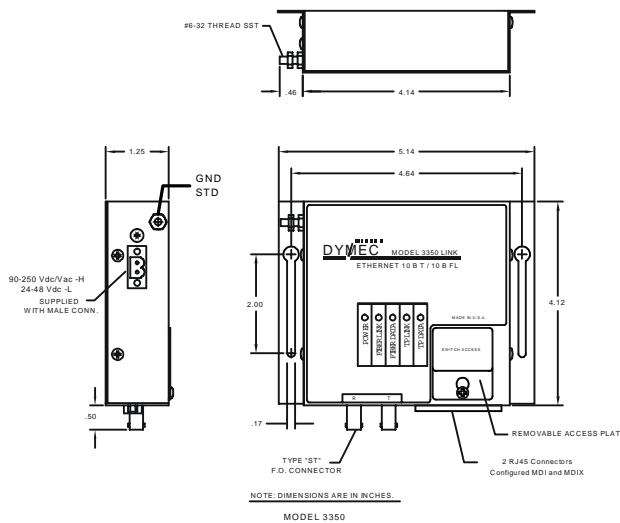

[www.dymec.com](http://www.dymec.com)