

Sacramento Utilities Department Chooses Magnum 6K25 Switches and S-Ring Redundancy Manager for Water Treatment Plant

An Industrial Ethernet Application

TECHNOLOGY TODAY

Water districts need to manage and monitor water intake and treatment facilities to provide high quality drinking water to their customers. Many plants have been in operation for decades, and most have some level of control system, often with legacy serial protocols. Serial protocols tend to be proprietary, and therefore expensive to implement.

As plants are being modernized, legacy serial data technology is being displaced with Ethernet packet data technology. Ethernet offers low components cost, high bandwidth, interoperability, and reliability including self-healing recovery from most LAN faults. Industrial Ethernet products, designed to meet the rigors of industrial environments, offer both more flexible and affordable communications systems and the high bandwidth required for today's information systems advances.

ABOUT SACRAMENTO WATER

A portion of the municipal water system for the City of Sacramento filters water from the Sacramento River through treatment plants that use chemical coagulation, flocculation, sedimentation, filtration, and disinfection. The Sacramento River Water Treatment Plant was placed in operation in 1924 when it had a 5 million gallon (mg) capacity. Over the years, improvements and modifications have increased the reliable treated water capacity to 100 mg per day, nearing the goal of renovations started in 1998 of achieving capacity of 160 mg per day.

THE CHALLENGE

The Sacramento River and E.A. Fairbairn Water Treatment Plants (established in 1964) account for 85 percent of Sacramento's water supply. The Sacramento River Water Treatment Plant's current intake structure was out of compliance with current environmental standards. As a part of the modernization project, CSDU (City of Sacramento Department of Utilities) chose to update its networking system as well. In developing the upgrade plan, CSDU wanted to use state-of-the-art technology that ensured a platform from which future upgrades could be expected to be integrated easily.

CSDU contracted with Saber Engineering, Auburn, CA for the controls system design, and Saber turned to Industrial Networking Solutions, Dallas, TX for assistance. Industrial Networking Solutions (INS) distributes network hardware and software designed and built specifically for the industrial marketplace.

THE SOLUTION

The new installations are based on a redundant ring topology, and utilize fiber media to support the distances required in managing the various SCADA (Supervisory Control and Data Acquisition) systems located throughout the City of Sacramento. The EMI noise immunity of fiber cabling increases operating reliability of the network. The installation uses the less expensive copper cabling for some local devices and computers within control system racks. Cost was an issue as the CSDU wanted to make its funds stretch as far as possible in upgrading the system.

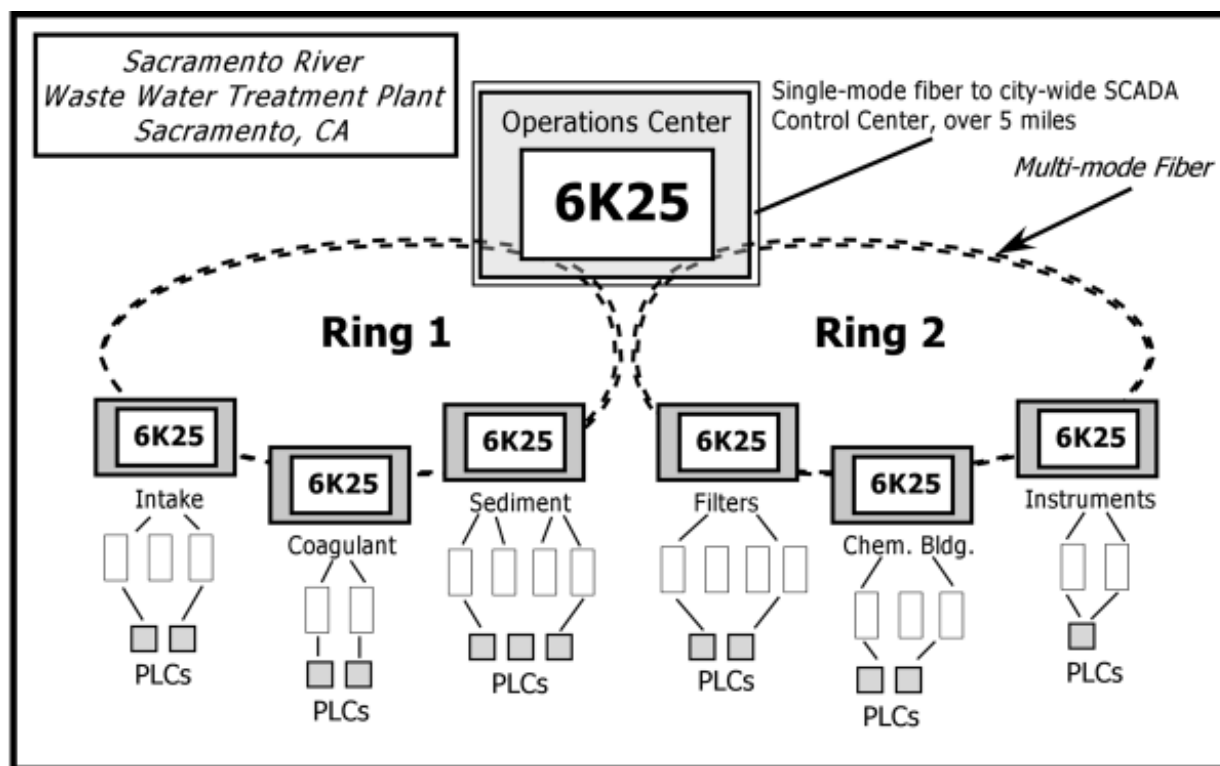

Sacramento Utilities Department

INS recommended Magnum 6K25 Fiber Switches and INS' iSNMP (industrial networking management protocol) Network Management Software. The 6K25 took advantage of GarrettCom's unique modular port structure that enables customers to define on a port-by-port basis the medium they need to use, providing immediate cost savings because of the efficiency of the units, and eliminating the need for media converters.

To ensure network reliability in the ring portion of the network, GarrettCom's S-Ring Redundancy Manager, based on the industry standard 802.1d Spanning Tree Protocol, is equally important. An added bonus was the management feature of the Magnum 6K25, which allows CSDU to monitor the health of the SCADA network as well as the health of the network system at the treatment plants without the necessity of full-time networking monitoring professionals at each site. The INS iSNMP allows monitoring of the network and hardware from the existing HMI software. No dedicated computer is required for the sole purpose of network monitoring and management. Immediate feedback when the monitoring system itself is in trouble can avert shutdowns and reduce the costs of managing and maintaining the networks.

Where proprietary serial lines are expensive and can max out in the multi-Kilobit (Kb) range, Ethernet protocols support 10 million bits (Mb) to 100 Mb per second, with migration paths to the 1 Gigabit (Gb) range and beyond. Cost benefits are equally impressive. Proprietary serial network interfaces average 40 times the cost of an Ethernet interface while providing 1/1000th of the bandwidth. Proprietary media converters for serial lines cost more than 10 times the price of an Ethernet media converter – and the need for them is eliminated by the Magnum 6K25 modular port structure and built-in fiber ports.

With the Ethernet network in place, the City of Sacramento will be able to easily implement technology advances such as video surveillance over the network with a minimum of effort and cost. While not in the current plans, the ability to implement these features in the future gives the City of Sacramento the ability to expand the remote monitoring and management of sites with reduced personnel expenses, thus adding to cost savings.

MAGNUM 6K25 MANAGED FIBER SWITCH

The Magnum 6K25 Managed Fiber Switch supports up to 24 built-in fiber ports with optional 1Gb fiber uplink capability. Unlike other managed switches available with industrial specifications, the Magnum 6K25 offers per-port configurability for RJ-45 connectors and 10 Mb fiber as well as the full range of 100 Mb fiber and Gigabit connector types.

Industrial users can take advantage of fiber's inherent noise immunity and extended distance support without the need for expensive, space-consuming media converters. The Magnum 6K25 Managed Fiber Switch comes with Managed Networks Software (MNS) that provides basic switch management, monitoring, and security. It is based on network standards and is easily integrated into existing networks.

Like all Magnum Plantwide LAN Ethernet products, the Magnum 6K25 Switch features extended operating temperature range, rack-mounting for IT centers, conformal coating optional to protect circuitry from exposure to high humidity and dust, high reliability, and high availability with a choice of AC worldwide power, and DC power from 125 VDC, 24 VDC, or -48 VDC sources.

S-RING REDUNDANCY MANAGER

The S-Ring Redundancy Manager enables Magnum 6K Managed Switches to simplify and speed up recovery from faults in Ethernet LAN configurations that use a ring structure. It is built upon networking software standards such as IEEE 802.1d Spanning Tree Protocol (STP). The user configures and controls S-Ring (patent pending) as part of the 6K Switch's LAN management software.

ABOUT GARRETTCOM

GarrettCom, Inc., is the leading manufacturer of industrial and carrier-class Ethernet LAN products. GarrettCom offers a comprehensive line of ETSI and NEBS-certified switches and hubs for use in telecommunications, industrial, and automated factory environments. GarrettCom markets its products through a network of resellers, OEMs, system integrators, and distributors worldwide. For more information on GarrettCom and its products, visit www.GarrettCom.com

©2003 GarrettCom, Inc. GarrettCom, Magnum, S-Ring, and Personal Switch are trademarks and Personal Hub is a registered trademark of GarrettCom, Inc. NEBS is a trademark of Telcordia Technologies. Ethernet is a trademark of Xerox Corporation. All other products and/or company names are trademarks of their respective owners.



GarrettCom[®]

Industrial Networking at Its Best™

GarrettCom, Inc.

47823 Westinghouse Drive • Fremont, CA 94539 • PH: (510) 438-9071 • FAX: (510) 438-9072

Email: mktg@garrettcom.com • Web: www.GarrettCom.com